



APOGEE™ DRIVE II

Installation guide for Intel processors using socket LGA 2011

What's Included in the box:

- Apogee™ Drive II Waterblock & integrated MCP35X pump, with spring-loaded retention screws and mounting brackets
- ½" Hose barb fittings & clamps
- Spare acrylic inserts in blue and green
- Tim-Mate Thermal compound

A word of caution before you begin

Like all other pumps in our product line (and the computer industry in general), the MCP35X pump which is built into your Apogee™ Drive II is not a self-priming pump. It means that the pump requires being filled-up and fed with a constant, air-free, supply of coolant in order to prime i.e. to circulate the fluid, and to *stay* primed. Upon initial installation it is therefore critical to make sure that the pump is completely full of fluid or it will spin without circulating the coolant. In order to facilitate this priming process, we recommend the following:

Case #1: The Apogee™ Drive II is being added as a secondary pump to an existing loop:

We will assume that the primary pump from your existing system has already been setup to prime properly, and no particular precautions for the installation of your Apogee™ Drive II are necessary. You may proceed with installation of the unit onto your motherboard (see the next step).

Case #2: The Apogee™ Drive II is the only pump in your loop:

During initial installation, and in order to enable adequate priming, it is essential that the pump be at the lowest point of your loop, in other words *that the coolant reservoir be placed above the pump when you start-it up*, and that the lines leading to, and exiting from the pump be full of coolant. Therefore, you might want to postpone fastening the Apogee™ Drive II to the motherboard **until after you have filled-up and primed the system**. Simply connect and secure the tubes to the Apogee Drive, and allow the unit to hang in the desired position while filling up and priming your loop. This is critical to understand because given the physical position of the Apogee Drive in the middle of the motherboard, there could be frequent instances where the reservoir is installed lower than the pump (at the bottom of the case for example), in which case you would never be able to prime it.

Once your Apogee Drive II has primed properly and the loop is full, then it is OK to install it to the motherboard, even if it is positioned higher than the coolant supply. As in any other cooling loop, always periodically check your coolant level to make sure that your pump always has its steady and air-free supply of coolant.



Installation to the Motherboard

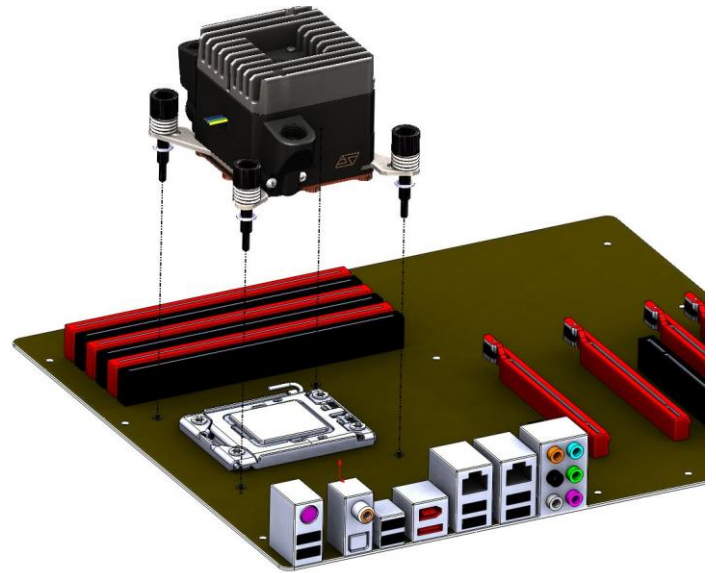

Clean the CPU with a degreaser (preferably formulated for electronics) then apply the supplied Tim-Mate thermal compound.

Lower the Apogee™ Drive II onto the CPU, and align the spring loaded screws with their respective mounting holes. Then fasten the screws alternatively and in a cross-pattern until they bottom out. The Apogee™ Drive II can be installed in any orientation with respect to the socket.

Electrical Installation

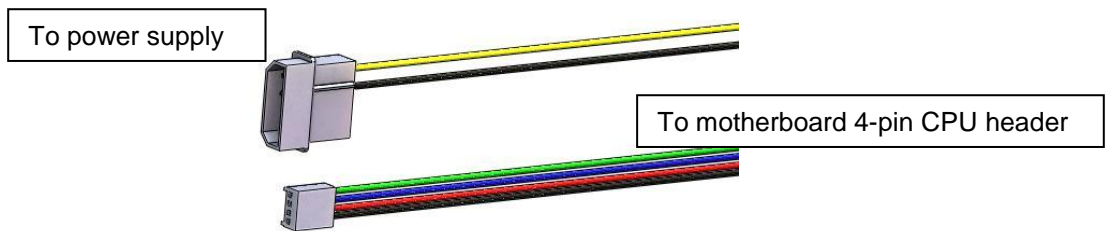

Hydraulic Installation



Attach the tubes to the hose-barbs, and secure them with the provided hose-clamps. The water-block inlet is specific, and indicated by an “IN” marking on the side of the waterblock housing.

Alternate orientation of the inlet and/or outlet ports

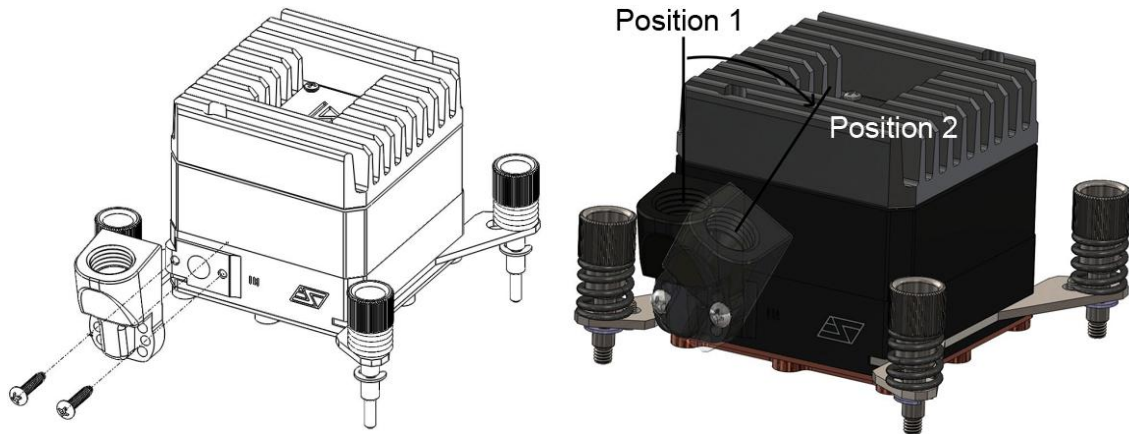

The inlet and outlet ports are installed straight up by default. They can also be installed at an angle to facilitate tube routing. To change the orientation of a port, loosen the 2 screws holding the port to the waterblock body and rotate the port until the holes match those in the waterblock, and then re-insert the existing screws.

Caution! Make sure that the port o-ring stays in place during installation!



Replacement of the acrylic insert

- Loosen the 4 screws holding the logo plate to the heatsink.
- Lift and set aside the logo plate.
- Lift the acrylic insert, and gently pull the LED out of it.
- Choose another colored acrylic insert and repeat the above steps in reverse.

Pump Operations and specifications

General Use

The MCP35X™™ pump is a magnetically driven centrifugal pump featuring a 12 V DC brushless motor. It requires no maintenance when used with de-mineralized water and the appropriate anti-fungal additives. We recommend using 10% Swiftech's HydrX™ as an additive. The pump is designed to be connected to your computer power supply using standard Molex connectors.

The pump features a second wire equipped with a 4-pin connector designed to connect to a motherboard PWM fan header (typically marked CPU_Fan), allowing speed control of the pump from 1300 to 4500 rpm. If not connected, then the pump defaults to its maximum 4500 rpm speed.

You can adjust the pump speed the same way you would adjust the CPU fan speed. This can be accomplished by adjusting the appropriate settings in the motherboard BIOS (please refer to your motherboard installation guide for specific how-to), or by using motherboard tweaking utilities.

The pump speed will then vary according to CPU temperature based on your own preferences.

The graph listed to the right shows the pump speed response as a function of the % PWM set in the BIOS.

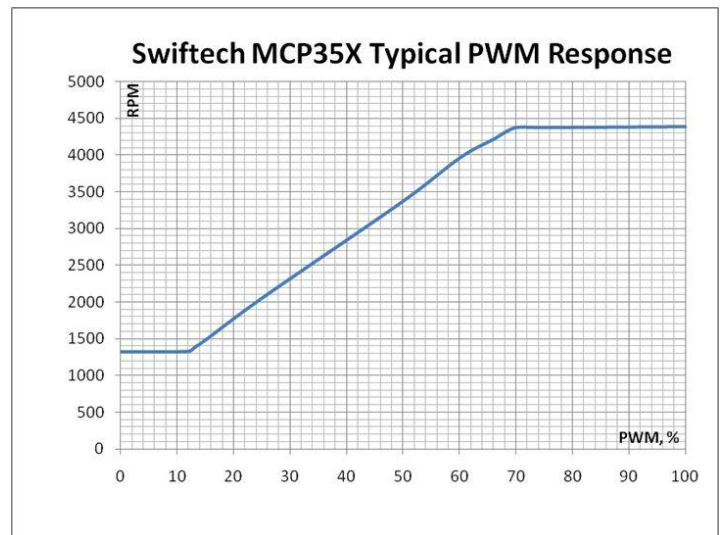



Pump operating precautions

The MCP35X™™ pump should never be run dry, even for a quick test. You should always prime the pump with fluid before you start operating it: see warranty note (*).

Use of coloring dyes or fluorescent additives containing particulate fillers will cause excessive wear to the pump's impeller bearing: see warranty note (**)

Pump Specifications

Motor type	Electronically commutated, brushless DC, spherical motor
Nominal voltage	12 V DC
Operating voltage range	9 to 13.4 VDC
Max. nominal power (@ 12 V)	18 W
Max. nominal current (@ 12 V)	1.5 A
Max. nominal head (@ 12 V)	14.7 ft (4.4m)
Max nominal discharge (@ 12 V)	Max nominal discharge (@ 12 V)
Maximum pressure	22 PSI (1.5 BAR)
Temperature range	Up to 140°F (60°C)
Electrical power connector	Molex 4 pin
PWM + RPM signals	4-pin connector
ROHS	Compliant
Port thread standard	G1/4
MTBF	50,000 Hours

Always double-check that fittings & plugs are correctly fastened to the block. The correct torque using a 5/8 (16mm) socket is ¼ turn past the point where the fitting is mated to the block surface.

ALWAYS TEST YOUR WATER-BLOCK FOR LEAKS PRIOR TO POWERING-UP YOUR COMPUTER!

DISCLAIMER: While all efforts have been made to provide the most comprehensive tutorial possible, Swiftech® assumes no liability expressed or implied for any damage(s) occurring to your components as a result of using Swiftech® cooling products, either due to mistake or omission on our part in the above instructions, or due to failure or defect in the Swiftech® cooling products. In addition, *Swiftech™ assumes no liability, expressed or implied, for the use of this product, and more specifically for any, and all damages caused by the use of this product to any other device in a personal computer, whether due to product failure, leak, and electrical short, and or electro-magnetic emissions.*

WARRANTY: This product is guaranteed for a period of 24 months from date of purchase for defects in material, and workmanship. Guarantee consists of replacing defective parts with new or reconditioned parts. Guarantee is considered void in case of improper use (*)(**), handling or negligence on the part of user. Original invoice showing date and place of purchase is required for exercise of the warranty.

(*) WARNING: DO NOT ATTEMPT TO RUN THIS PUMP DRY. THIS WILL CAUSE IMMEDIATE AND PERMANENT DAMAGE TO THE PUMP.

(**) EXCESSIVE WEAR DUE TO INADEQUATE FLUIDS.

During this period, they will be repaired or have parts replaced provided that: (I) the product is returned to the agent from which it was purchased; (II) the product has been purchased by the end user and not used for hire purposes; (III) the product has not been misused, handled carelessly, or other than in accordance with any instructions provided with respect to its use. This guarantee does not confer rights other than those expressly set out above and does not cover any claims for consequential loss or damage. This guarantee is offered as an extra benefit and does not affect your statutory rights as a consumer.