

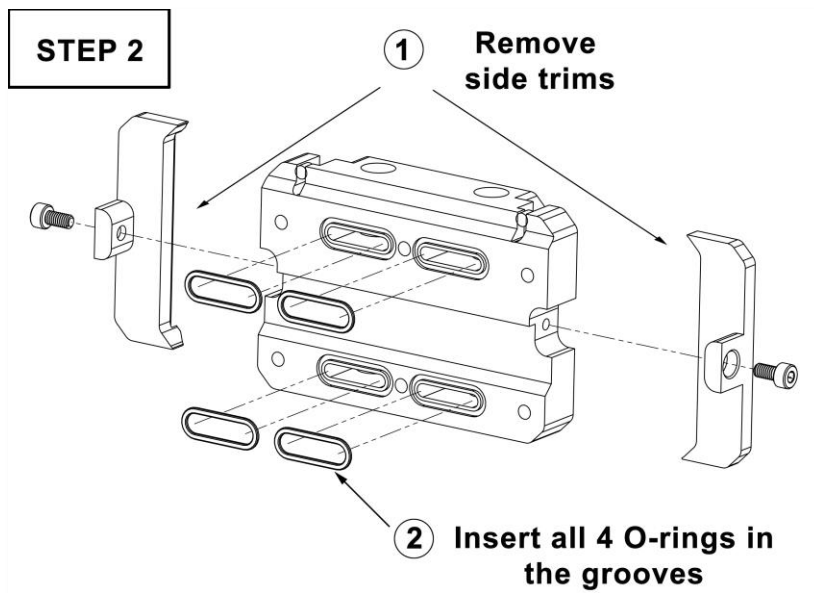

Universal SLI/Crossfire Luxury Edition Dual Bridge for Komodo Waterblocks

QUICK INSTALLATION GUIDE – GUIDE D'INSTALLATION – GUÍA D'INSTALACION

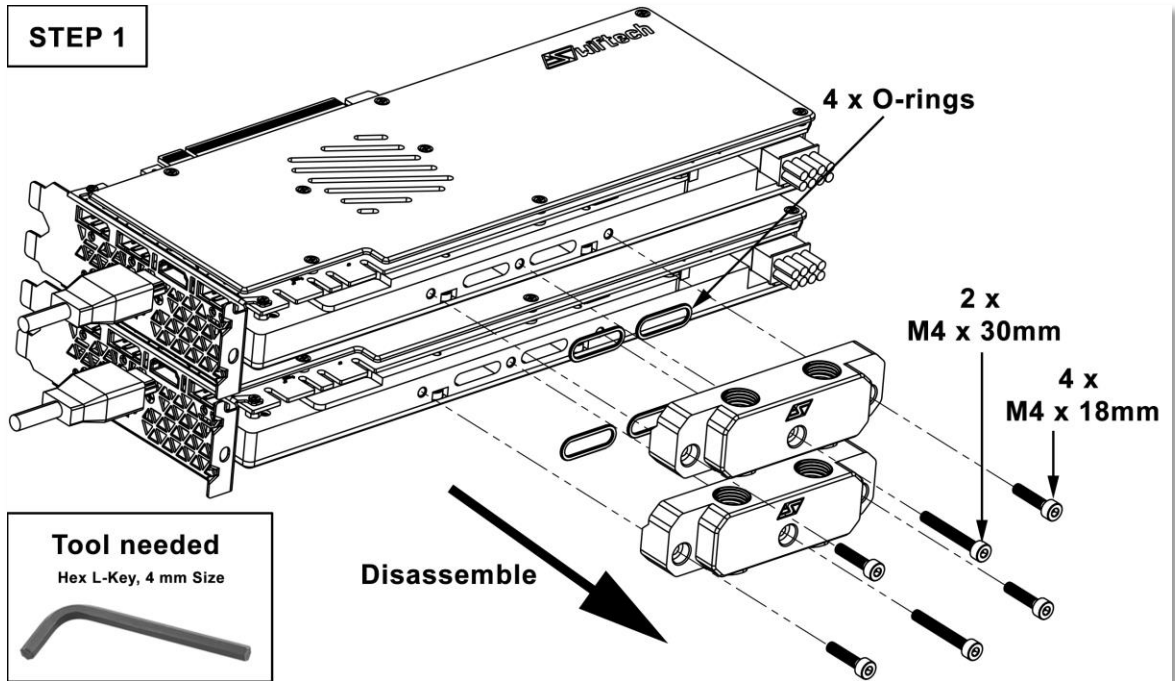

STEP 3

Caution: do not forget the O-RINGS! (from step 2)

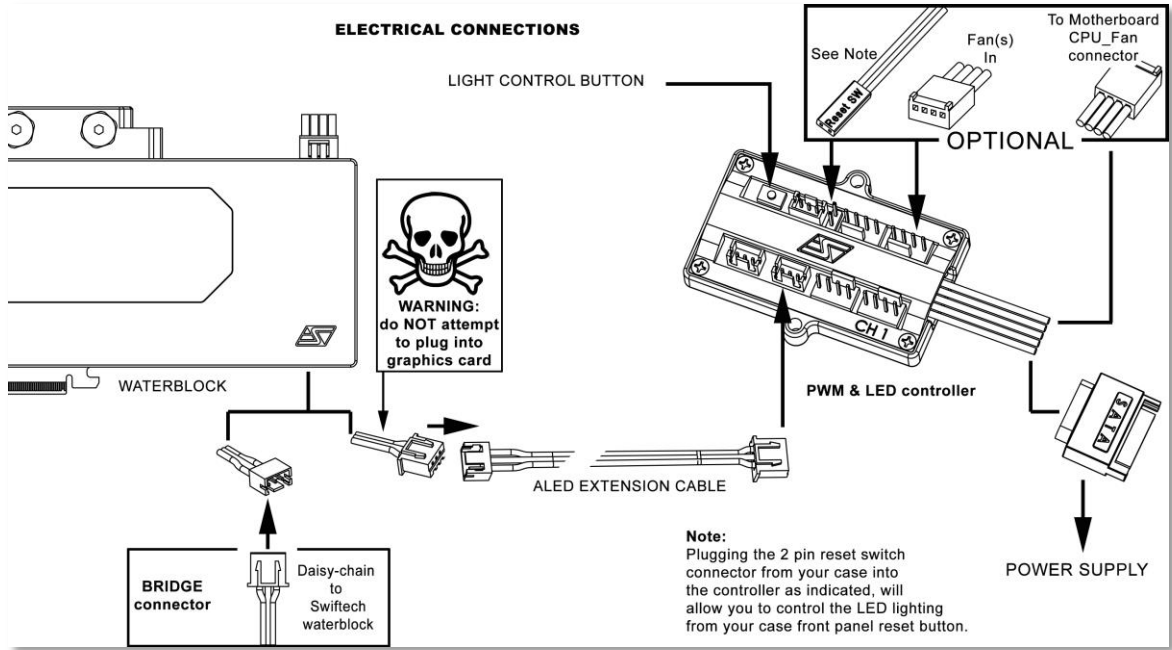
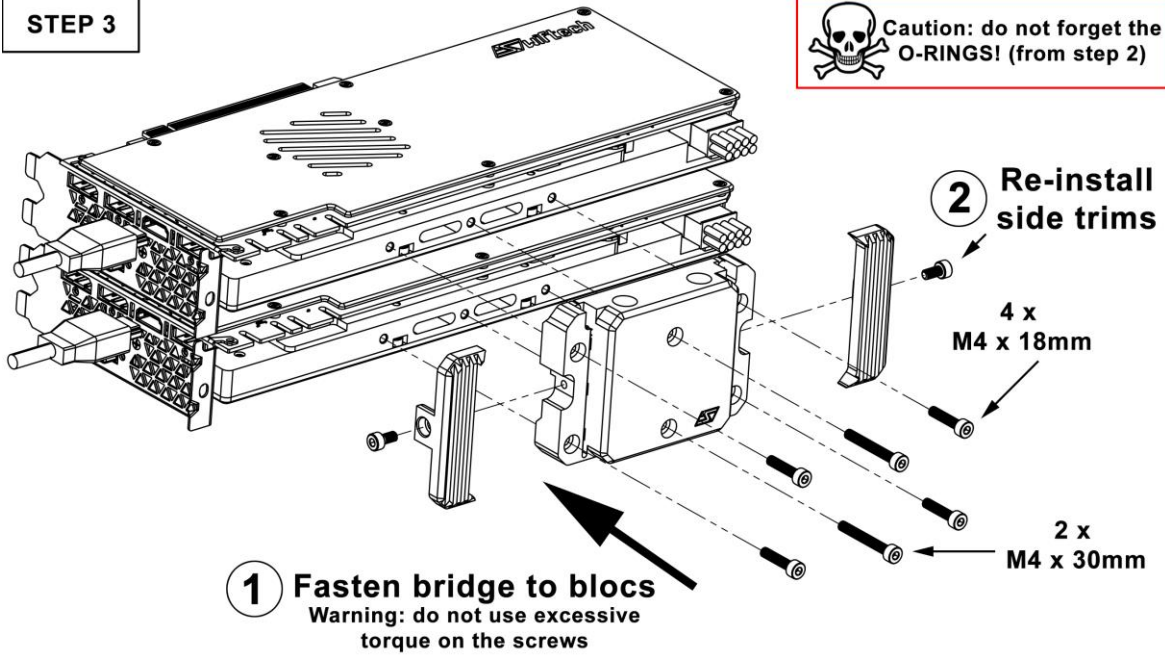

SAFETY FIRST!
ALWAYS TEST YOUR BLOCK FOR LEAKS PRIOR TO POWERING UP YOUR SYSTEM!

DISCLAIMER: While all efforts have been made to provide the most comprehensive tutorial possible, Swiftech® assumes no liability expressed or implied for any damage(s) occurring to your components as a result of using Swiftech® cooling products, either due to mistake or omission on our part in the above instructions, or due to failure or defect in the Swiftech® cooling products. In addition, Swiftech™ assumes no liability, expressed or implied, for the use of this product, and more specifically for any, and all damages caused by the use of this product to any other device in a personal computer, whether due to product failure, leak, and electrical short, and or electro-magnetic emissions. **WARRANTY:** Our products are guaranteed for 12 months from the date of delivery to the final user against defects in materials or workmanship. During this period, they will be repaired or have parts replaced provided that: (I) the product is returned to the agent from which it was purchased; (II) the product has been purchased by the end user and not used for hire purposes; (III) the product has not been misused, handled carelessly, or other than in accordance with any instructions provided with respect to its use. This guarantee does not confer rights other than those expressly set out above and does not cover any claims for consequential loss or damage. This guarantee is offered as an extra benefit and does not affect your statutory rights as a consumer.