

MCW20-A™ WATER-BLOCK

Installation guide - AMD® platforms

Parts list

Parts	QTY	PARTS	QTY
MCW20-A™ assembly	1	Nylon tension limiter	2
4-40 x 1 1/2" Philips screws	2	Spring	2
Black fiber washers	6	Knurled knobs	2
4-40 mini-nuts	2	Tube inserts	2
Arctic Alumina Thermal compound	1		

This product is intended for expert users. Please consult with a qualified technician for installation. Improper installation may result in damage to your components. Swiftech assumes no liability whatsoever, expressed or implied, for the use of these products, nor their installation. The following instructions are subject to change without notice. Please visit our web site at www.swiftnets.com for updates.

1. **Before you install the MCW20-A™ water-block:**

a. **Prepare two pieces of tubing** of sufficient length to connect to the rest of your circuit. The cuts must be square as shown in figure 1 or leaks may occur:

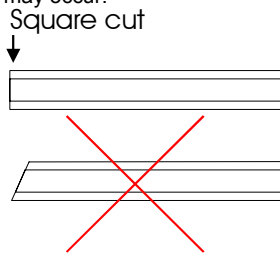

Figure 1

b. **Install the provided plastic tube inserts** at each end of the tubes, as shown in figure 2: these inserts are absolutely **imperative** when using any kind of **soft** tubing, such as vynil, ClearFlex, Taigon, etc...



Figure 3



Figure 4

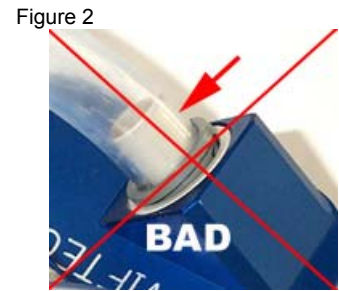

Figure 5

c. **Spread a little bit of grease or liquid soap** around the tubing. It helps pushing the tubes in, particularly with Clearflex™ tubing, which features a very "sticky" surface.

d. **Fully insert both tubes into the fittings.** The tip of the plastic tube inserts should be flush with the inlet and outlet openings, as shown in figure 4 above. Inserting the tubes requires a firm push, accompanied by a twisting motion.

2. **Preparing your Motherboard**

- Remove the motherboard from the chassis
- Remove the existing heat sink
- Carefully clean the microprocessor, using alcohol

3. **Installing the MCW20-A™ water-block with AMD® platform motherboards**

- Install the provided screws through the motherboard, using a black fiber washer on both sides of the motherboard, and tighten the nuts.
- Install the motherboard in the chassis
- Lightly coat the microprocessor with the provided thermal compound. Only a paper-thin coat is necessary. It should be applied using preferably a razor blade, or a credit card, held between thumb and index at a 45-degree angle.
- TIP! It is preferable to have the tubing inserted into the water-block BEFORE you install the block onto the motherboard. This is because pushing the tubes into the block while it is already installed could exert undue pressure onto the microprocessor.**
- Slide down the MCW20-A over the retention screws, then install the nylon tension limiters (flange facing down), the springs, and tighten the assembly with the knurled knobs. Over tightening of the assembly is prevented by the tension limiter. Users should be cautious nonetheless, as nylon can be easily crushed.

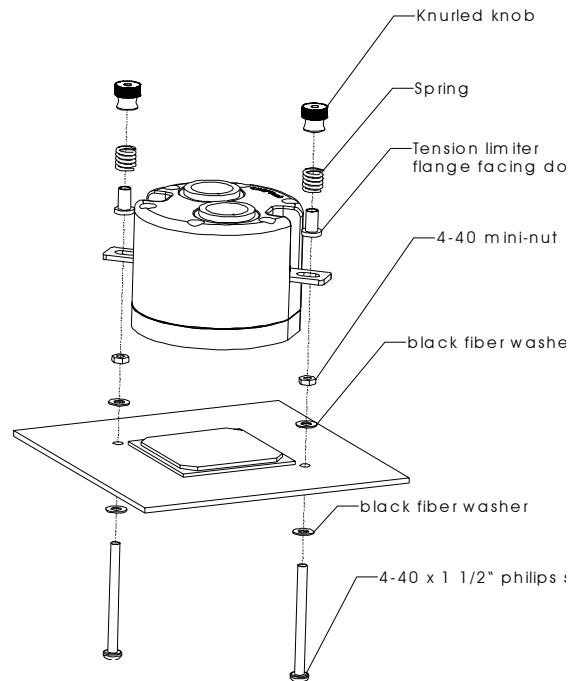

4. Connect the block to the rest of the cooling circuit.

The block is designed in such a way that it will bleed itself automatically in any vertical orientation (computer standing-up) .

5. Type of Coolant:

- a) For best performance, use 95% distilled water, and 5% Swiftech brand "HydrX" corrosion inhibitor (available here: <http://www.swiftnets.com/store/category.asp?CatID=2>, under the "accessories" section).
- b) In ALL cases, you MUST use Distilled water AND a corrosion inhibitor with the MCW5002 water-block. Regular automotive anti-freeze is acceptable. Automotive manufacturers recommend that not less than 25% is used.
- c) NEVER use tap water, even for a short-term test.
- d) Not following paragraphs b and c above constitutes misuse (*) of the product, and will void your warranty.

6. Final inspection

Once the installation is completed, **it is always a good idea to test the circuit for leaks, prior to powering up the computer.** Troubleshooting help is available on our web site at www.swiftnets.com, or by calling customer support at 562-595-8009.

Note concerning removal of the tubing: Push in collet squarely against face of fitting, using swiftech's tube removal tool, or a wrench of approximately the same opening diameter as the tube (1/2" +). With the collet firmly held against the face of the fitting, the tube can be safely pulled out. Do not attempt to pull the tube out without pushing squarely against the collet. This may result in damaging the fitting.

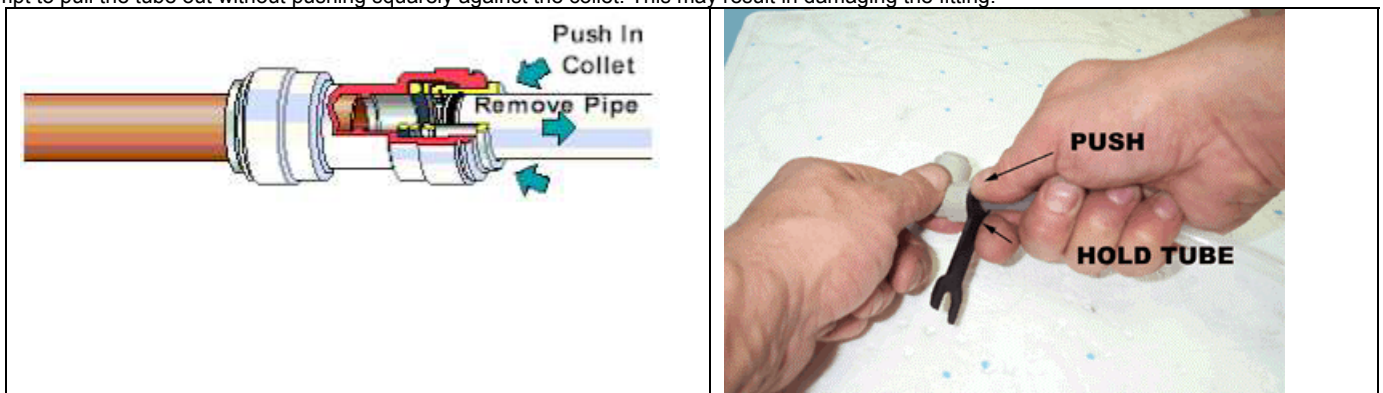

IMPORTANT DISCLOSURES

While all efforts have been made to provide the most comprehensive tutorial possible, Swiftech assumes no liability expressed or implied for any damage(s) occurring to your components as a result of using Swiftech cooling products, either due to mistake or omission on our part in the above instructions, or due to failure or defect in the Swiftech cooling products.

WARRANTY

Our products are guaranteed for 12 months from the date of delivery to the final user against defects in materials or workmanship. During this period, they will be repaired or have parts replaced provided that: (I) the product is returned to the agent from which it was purchased; (II) the product has been purchased by the end user and not used for hire purposes; (III) the product has not been **misused (*)**, handled carelessly, or other than in accordance with any instructions provided with respect to its use. This guarantee does not confer rights other than those expressly set out above and does not cover any claims for consequential loss or damage. This guarantee is offered as an extra benefit and does not affect your statutory rights as a consumer.