

MCW5000-PT™

THERMOELECTRIC WATER-BLOCK INSTALLATION GUIDE

Parts list

Parts	QTY	PARTS	QTY
Water-block, with TEC & gaskets assy.	1	Arctic Alumina Thermal compound	1
Tube inserts	4	Hex L-key	1
Tube removal tool	1	Euro-style connector	1
Motherboard installation hardware pack	1		

This product is intended for expert users only. Please consult with a qualified technician for installation. Improper installation may result in damage to your components. **Swiftech assumes no liability whatsoever, expressed or implied, for the use of these products, nor their installation.** The following instructions are subject to change without notice. Please visit our web site at www.swiftnets.com for updates

1. Before you install the MCW5000-PT™ water-block:

Prepare two pieces of tubing of sufficient length to connect to the rest of your circuit. It is preferable to insert the tubing into the block **BEFORE** it gets installed onto the CPU, to prevent placing undue pressure onto the assembly when it is installed on the CPU.

The cuts to the tubing must be square as shown in figure 1 or leaks may occur. Use a good pair of scissors to cut the tubing. It is easier than with a razor blade.

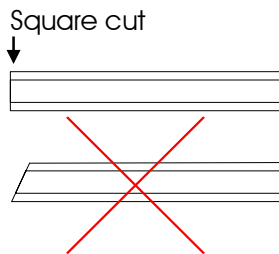

Figure 1

Install the provided plastic tube inserts at each end of the tubes, as shown in figure 2: these inserts are absolutely **imperative** when using any kind of **soft** tubing, such as vynil, ClearFlex, Taigon, etc...



Figure 2



Figure 3

c. **Spread a little bit of grease** (Vaseline etc..) around the tubing. It helps pushing the tubes into the fittings.



Figure 4



Figure 5

d. **Fully insert both tubes into the fittings.** The tip of the plastic tube inserts should be flush with the inlet and outlet openings, as shown in figure 4 above. Inserting the tubes requires a firm push, accompanied by a twisting motion.

2. Preparing the motherboard

Install the standoffs in the Motherboard

You must uninstall your MB prior to installing the MCW5000-PT™ water-block.

Remove the stock heatsink retention frame (the black plastic frame that clips down to your motherboard). This will reveal the four mounting holes we use to install our standoffs.

Install a standoff in each one of the holes. Keep the standoff centered over the MB holes, and secure with hex locknuts and a fiber washer on backside of the MB. Torque value not to exceed 16 in. lbs

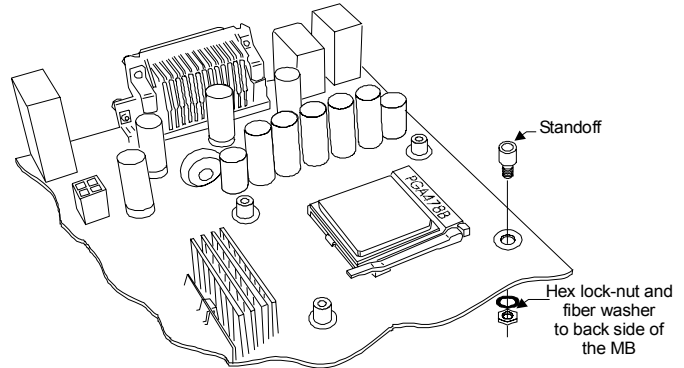

Figure 6

Fill-up the socket with dielectric grease.

Do not confuse dielectric grease with thermal compound. Dielectric grease is used to prevent condensation where parts are exposed to cold. We recommend Lubrex (available on our web site under the accessories section), or any similar product, with good dielectric properties. Fill-up the socket center cavity (grease is to be level with the upper surface of the socket), and coat the socket pinholes with grease. Spread the grease with your finger so that it will penetrate inside the pinholes.

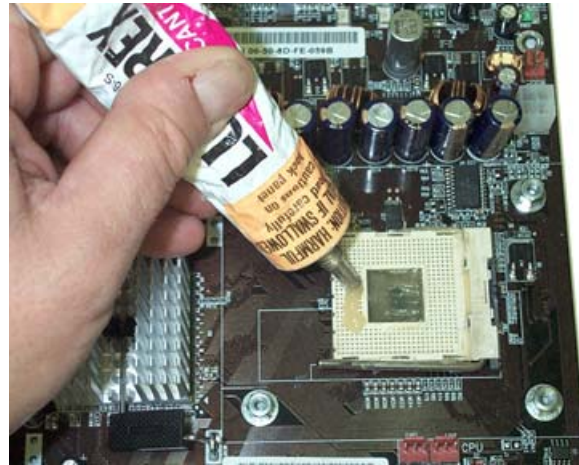

Figure 7

Insert the processor into the socket.

Since you have grease inside the socket, some hydraulic pressure lift may occur: for this reason, make sure that the processor sits perfectly flat, and is inserted all the way into the socket. Then, coat the processor core with high quality thermal compound. **Only a paper-thin coat is necessary.** It should be applied using preferably a razor blade, or a credit card, held between thumb and index at a 45-degree angle.

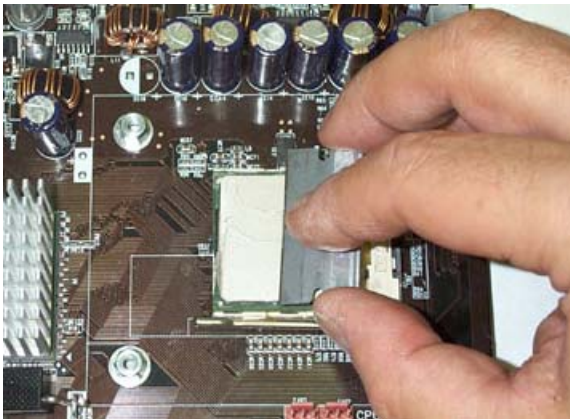

Figure 8

Remove the peel-off paper back from the motherboard gasket, and install it as shown Figure 9. The sticky side should be towards the motherboard.

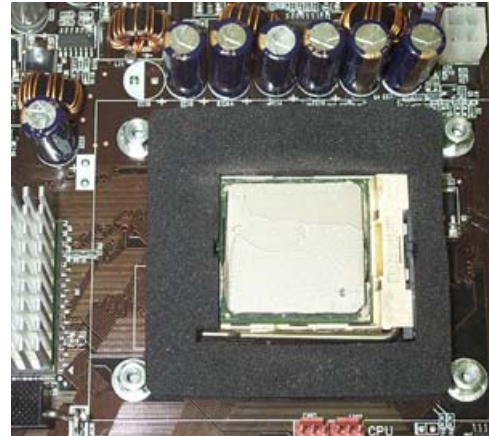

Figure 9

Install the water-block assembly onto your processor, as shown on figure 10.

Gradually tighten the screws in a crisscross pattern until you feel that they reach the bottom of the standoff. A “finger-tight” lock is sufficient. Conversely, adjustments such as tightening the screws only partially are **strictly prohibited**. Such attempts will result in improper contact between the CPU core and the heat sink, and result in CPU overheating.

To further prevent condensation to occur behind the motherboard, a neoprene sticker is provided with your water-block accessories. **Apply it to the back of the motherboard, behind the processor.**



Figure 10

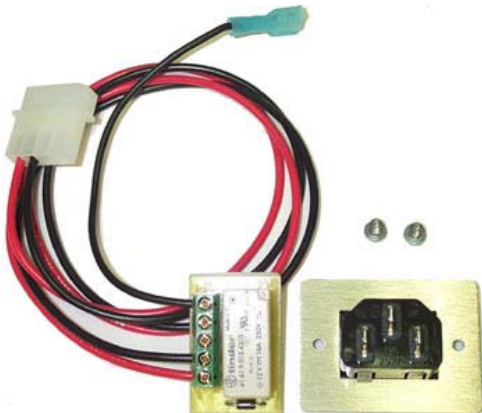

Figure 11

CRITICAL INSTRUCTIONS:

Never run a thermoelectric module without coolant flowing into the circuit. This will result in catastrophic failure of the cooling circuit, and may cause any/all of the following:

- tubing to burst open due to coolant overheating
- permanent failure of the Peltier module
- permanent damage to the CPU and/or motherboard due to excess heat

It is highly recommended to dedicate the auxiliary power supply for the thermoelectric module to the computer power-supply, so that the Peltier module will never run by itself without circulating coolant. For this purpose, we recommend the following accessory, available in our online shopping cart:

PRS Kit II,

Includes:

Relay Switch Circuit board AC socket, S/S socket cover, power cord

This relay switch is rated for 110 to 220~240 volts and up to 50A inrush current. It is suitable for use with the S-320-12 Meanwell power supply recommended in paragraph 3, page 4.

If you run your computer unattended for extended periods of time, it is also a good practice to setup an alarm temperature, which will shut down the computer in case the CPU overheats. Such alarm/shut down process should be tested as functional.

Now, you can re-install the MB inside the case.

3. Thermoelectric installation

IMPORTANT WARNING: Solder joints of the wires to the thermoelectric module are **extremely fragile**. Bending the wires at their root will break the solder joint, with no possible repair. **Swiftech will not honor the warranty for broken wires.**

Connection to a dedicated auxiliary power supply (recommended):

The TEC module is provided with "bare wires" to facilitate installation with screw type terminals. We recommend the "Meanwell S320-12" power supply, available on our website in the Thermoelectric accessories section.

Connect red wire from TEC module to the +V terminal, and black wire to the -V terminal as shown in figure 3 below:

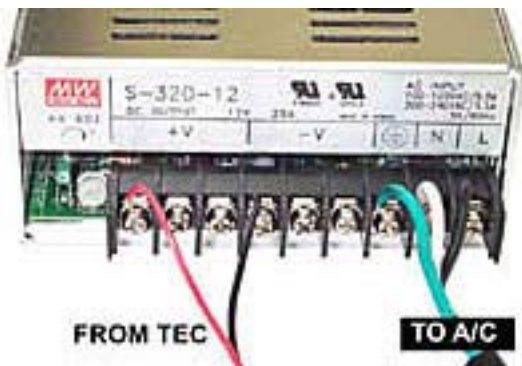

Minimum requirements for a dedicated power supply: 25A @ +12 V. If adjustable voltage is available: setting the voltage higher than +12V is not recommended. Lower voltage, can be safely used, down to 9 volts.

Connection to an ATX computer power supply:

Important Warning: to connect the MCW5000-PT cooler to an ATX computer power supply, you must carefully consider the existing requirements of other devices connected on the +12V line. Connecting to an underpowered unit will definitely damage the power supply.

Minimum requirements for an ATX computer power supply: 37A at +12V in a typical computer setup.

If you are nevertheless going to connect the MCW5000-PT to a computer power supply, you need to cut the wiring to one of the power supply Molex connectors, and use a different connector between power supply, and thermoelectric. This is because Molex connectors are not rated for 25 Amps current, and may overheat.

Use a euro-style wire connector as shown in fig 4 below, or similar device with a current rating of at least 25 amps. Connect red wire from TEC module to +12V of P/S (Yellow wire), and black wire to black wire:

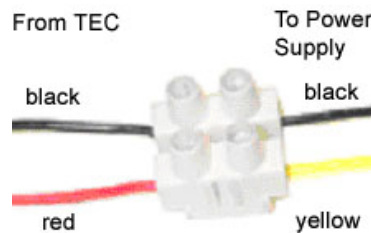

If you need wiring extensions: use 16 gage stranded wire. Connect the extension to the existing wires with **terminal splices**, or solder the butts, and insulate with shrink tubing.

4. Connect the MCW5000-PT block to the rest of the cooling circuit.

The block is designed in such a way that it will bleed itself automatically in any vertical orientation (computer standing-up).

5. Final inspection

Once the installation is completed, **it is always a good idea to test the circuit for leaks, prior to powering up the computer.** Troubleshooting help is available on our web site at www.swiftnets.com, or by calling customer support at 562-595-8009.

Note concerning removal of the tubing in quick-connect fittings: Push in collet squarely against face of fitting. A tube removal tool is provided with the MCW5000-PT block. With the collet firmly held against the face of the fitting, the tube can be safely pulled out. Do not attempt to pull the tube out without pushing squarely against the collet. This may result in damaging the fitting. Further details for using quick-connect fittings are also available here: http://www.johnquest.com/install_6.shtm#disconnect:

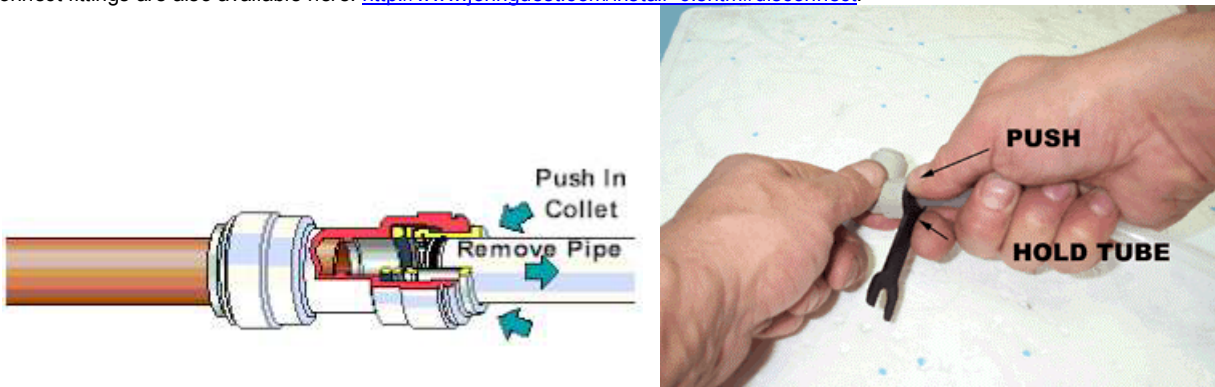

DISCLAIMER: Swiftech assumes no liability whatsoever, expressed or implied, for the use of these products.