

MCX370-A™ & MCX370-C™ Heatsinks Installation Guide

Packing list

Parts	Qty	Parts	Qty
Heat Sink	1	Nylon spacers	2
Fan	NO	Long spring	1
6-32 x 2 1/2" screws (for fan)	4	Short spring	1
6-32 x 1" screws (for HS)	2	Rubber washers	8
Clips	2	Thermal grease	1

Compatible with AMD® Duron™, Athlon™, MP, XP 2000 & higher, and Intel® Pentium™ III processors

I. Assembly schematic

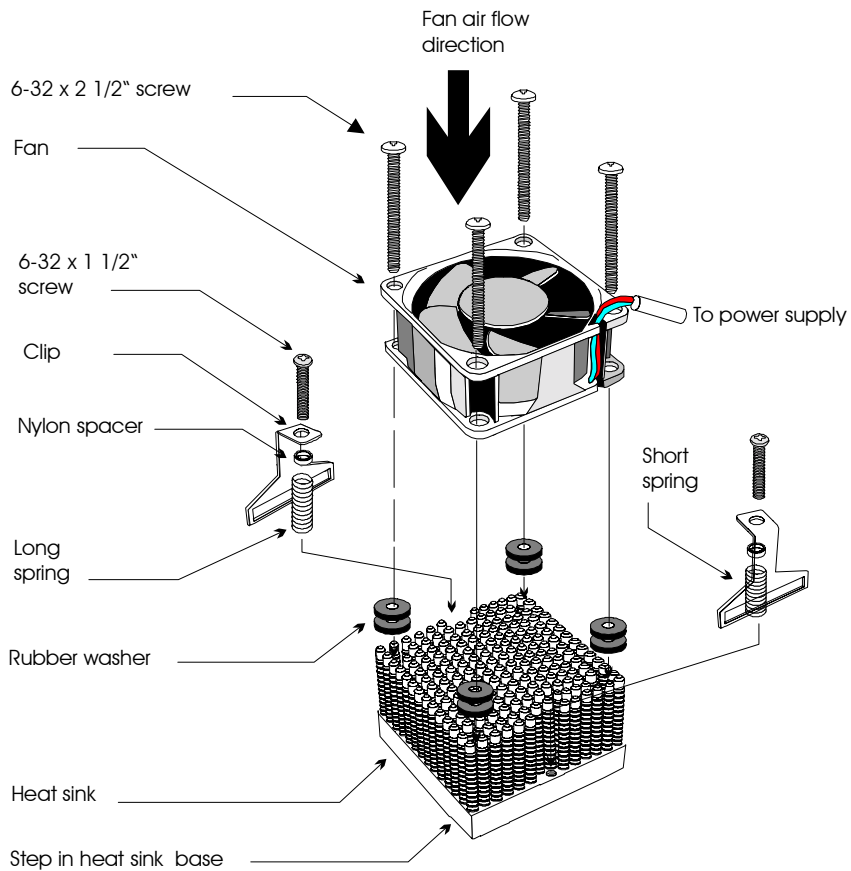

II. Heat sink Installation

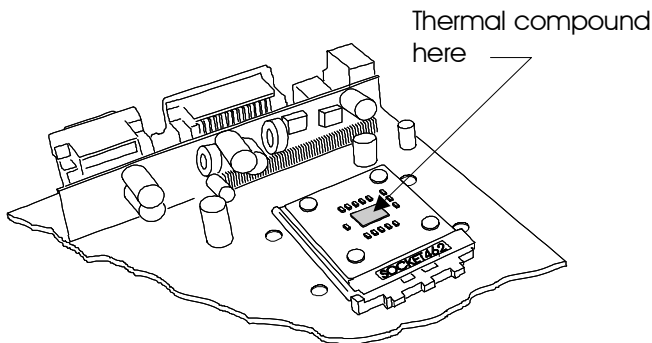

- We recommend that you lay down your computer flat on a table.
- Lightly coat the processor core with the included thermal compound. **Only a paper thin coat is necessary.** It should be applied using preferably a razor blade, or a credit card, held between thumb and index at a 45 degree angle. It is critical to ascertain that the entire core is covered with a uniform coat of thermal compound. Thermal performance will dramatically decrease if any portion of the core is not covered by thermal compound.

- The heat sink base features a step which should be placed over the socket's cam box as shown in schematic to the right.
- Place the heat sink fan assembly onto the CPU making sure that the clips hook to the tabs on each side of the socket. Should the factory setting be a little short, do not attempt to force the heat sink down by rocking it one side or another. Simply screw clockwise until the clips hook onto the tabs.
- Then, turn both screws counter-clockwise until the head of the screw clears the top of the clip by approximately 1/16" (1.5mm) as shown in the picture below. As soon as the head of the screw is no longer touching the top of the clip, the spring is under full tension.



Turn screw driver
counter clockwise to
 secure assy.
 To CPU

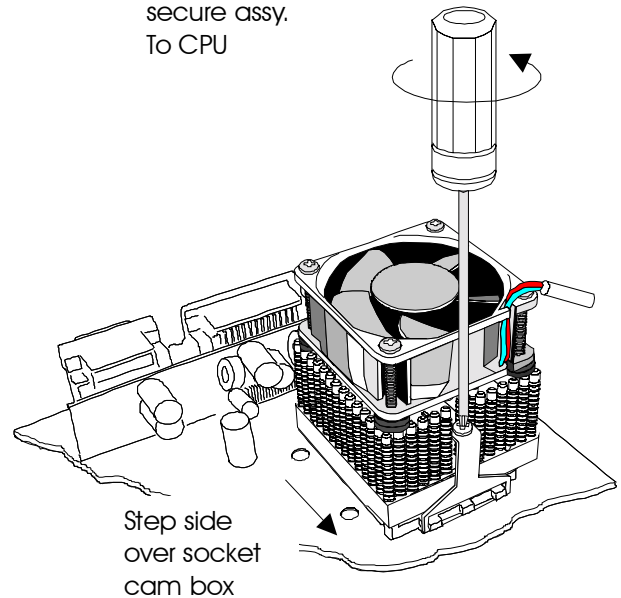

- Note: Should you disassemble the mounting screws and compression springs for any reason in the future, please note that the springs are of unequal length. The short spring goes on the side of the heat sink that features a step in the base, whereas the long spring goes to the opposite side (see assy. schematic on page 1).
- Finally, connect the fan power cord to the power supply.

III. Final inspection

Now that the heat sink is installed, startup your computer, go into the BIOS and observe the CPU temperature. Under normal ambient temperature conditions, the processor temperature should never exceed 60° C (140 ° F). If it does, shut down the computer immediately, and review your entire installation. Troubleshooting help is available on our web site at www.swiftnets.com, or by calling customer support at 562-595-8009.

DISCLAIMER: Swiftech assumes no liability whatsoever, expressed or implied, for the use of these products.