

**H2O-220 APEX
"ULTIMA PLUS"
LIQUID COOLING KIT**

TUTORIAL & INSTALLATION GUIDE

**Water
cooling
Swiftech**

manufacturer of the world's best active coolers

These instructions are updated on a regular basis. Please visit our web site at www.swiftech.com

Packing List

QTY	ITEM
1	APOGEE GTZ water-block, including socket 775 and socket 1366 hold-down plates for Intel Core® (Core 2, Duo, Quad, Extreme, i7) series of micro-processors. <u>Important note:</u> Free Upgrade available (see terms and conditions) for AMD® socket 754, 939, and AM2, as well as Intel® socket 603-604 and 771 (for Xeon™ series) Server form factor
1	MCW60 VGA water-block, including standard hold-down plate & mounting hardware, GT200 adapter kit, and (2) ½" hose clamps
1	Pack of 8 MC14 VGA Ramsinks, and 4 MC21 Mosfet heatsinks
1	MCW30 Chipset water-block, including hold-down plates and mounting hardware, and (2) ½" hose clamps
1	MCP655-B pump, including mounting hardware and (2) ½" hose clamps
1	MCRES-Micro Rev. 2, including ½" hose-barb fittings, and hose clamps, bracketry & hardware for various installation: 1 "L" bracket, 2 "U" brackets
1	MCR220 Radiator assembly, including (2) pre-installed 120mm fans with fan guards, mounting hardware, ½" black nylon hose barb fittings, (2) 12v to 7v adapters, (2) 12v to 5v 3-pin to 4-pin Molex adapters, and (2) hose clamps And Pre-installed MCB-120 Radbox, with mounting hardware
8	Feet 7/16" industrial grade PVC tubing
1	Length (40") Smartcoils 625 blue
1	2 Oz. Bottle of HydrX concentrated coolant
1	Syringe of Arctic Céramique thermal compound

Warning!

The Apogee GTZ water-block included with your kit is compatible with all the most popular processors available on the market. In an effort to cut on waste however, some of the less popular mounting mechanisms have not been physically included in the kit and are available for free on demand. They are:

- Hold-down plate for Intel® legacy server platforms (socket 603-604, and 771 for Xeon™)
- Hold-down plate for AMD® socket 754, 939, F and AM2

If you own one of the above platforms, all you have to do is contact customer support and the part will be shipped to you at no charge by express mail or equivalent. The following terms and conditions apply:

Worldwide except Europe:

Please email within 90 days of your date of purchase (proof of purchase required), call, write or Fax to Swiftech customer service at:

TOLL FREE (Continental US only) 1-888-85SWIFT (1-888-857-9438)

Mailing Address	Swiftech 3700 Industry Ave., suite 104 Lakewood, CA 90712 USA
Telephone	(562) 595-8009
Fax	(562) 595-8769

Europe: Please email rma@bacata.net within 90 days of your date of purchase (proof of purchase required)

TABLE OF CONTENTS

I.	PLANNING	4
1.	General Guidelines	4
2.	Tube Routing	4
II.	INSTALLATION OF THE COOLING COMPONENTS	5
1.	MCR220 Radiator installation	6
	<input type="checkbox"/> General concept schematic	6
	<input type="checkbox"/> Installation	7
2.	APOGEE GTZ Water-block installation	8
	<input type="checkbox"/> Installation with Intel® socket 775, Core™ 2, Core Duo, Extreme (default water-block configuration)	8
	<input type="checkbox"/> Installation with Intel® socket 1366, Core™ i7 Desktop Solutions - Removal of the default hold-down plate required.....	9
	<input type="checkbox"/> Installation with Intel® socket 1366 (Core™ i7) Server Solutions.....	10
	<input type="checkbox"/> Installation with Intel® legacy server platforms (socket 771, Xeon).....	10
	<input type="checkbox"/> Installation with AMD® socket 754, 939, F and AM2	10
3.	MCW30 Chipset water-block installation	10
4.	MCW60 VGA water-block installation	10
5.	Re-installing the motherboard	11
6.	Pump installation	11
	<input type="checkbox"/> General Use	11
	<input type="checkbox"/> Physical installation.....	11
	<input type="checkbox"/> Pump operating precautions:	11
7.	MCRES-Micro reservoir Installation	12
	<input type="checkbox"/> Installation.....	13
	<input type="checkbox"/> Preparing the coolant.....	14
8.	Installing the tubing	15
9.	Completing the installation	15
	<input type="checkbox"/> Re-installing your power-supply.....	15
	<input type="checkbox"/> Filling-up the circuit.....	16
10.	Troubleshooting	17
11.	Draining the system	17
12.	Periodic Maintenance	17
13.	Optional Components	17

INTRODUCTION

Congratulations on your purchase of a Swiftech™ H2O-APEX liquid cooling system!

This kit has been designed to facilitate the installation of the components with a minimum of case modifications. While all attempts have been made to make the installation of this system user friendly, please note that this system is intended for users that are well versed in installing computer components.

DISCLAIMER

While all efforts have been made to provide the most comprehensive tutorial possible, Swiftech assumes no liability expressed or implied for any damage(s) occurring to your components as a result of using Swiftech cooling products, either due to mistake or omission on our part in the above instructions, or due to failure or defect in the Swiftech™ cooling products.

In addition, Swiftech assumes no liability, expressed or implied, for the use of this product, and more specifically for any, and all damages caused by the use of this product to any other device in a personal computer, whether due to product failure, leak, electrical short, and or electro-magnetic emissions.

WARRANTY

Our products are guaranteed for 12 months from the date of delivery to the final user against defects in materials or workmanship. During this period, they will be repaired or have parts replaced provided that: (I) the product is returned to the agent from which it was purchased; (II) the product has been purchased by the end user and not used for hire purposes; (III) the product has not been misused, handled carelessly, or other than in accordance with any instructions provided with respect to its use. This guarantee does not confer rights other than those expressly set out above and does not cover any claims for consequential loss or damage. This guarantee is offered as an extra benefit and does not affect your statutory rights as a consumer.

I. Planning

1. GENERAL GUIDELINES

- Please read this guide carefully and entirely before you start this installation. Plan your installation ahead. Observe the relative position of the components for possible interference with other components.
- Never work with electricity connected to the computer while work is in progress.
- Because some work is necessary that will require cutting holes in the case, it is strongly recommended to remove all the components from the case prior to begin with this installation.
- After the metal work has been completed, carefully clean the case to remove all metal debris.
- Once the time has come to re-install the motherboard and complete the liquid-cooling circuit, the motherboard should be disconnected from the power-supply at all times during the entire mock-up phase of the installation. In case of a spill or leak on the motherboard, do not panic! As long as the motherboard is not electrically connected, no harm is done. You must however thoroughly dry the exposed area, using a hair dryer for example, and wait a minimum of 6 to 8 hours prior to re-connecting the motherboard to its power source.
- The reservoir should preferably be installed at the highest point of the cooling circuit (top 5 ¼" tray), although this is not absolutely necessary if all the other components are self-purging.
- Think about the airflow inside your chassis. In liquid-cooling environments, it is always better to draw fresh air from the outside through the radiator, as opposed to using the warm air from inside the computer.
- Make sure to dry-fit all components before making final connections and filling the water-cooling system.

2. TUBE ROUTING

- The tubing for the water-cooling system must be routed to form a complete loop that includes all elements of the system. When daisy-chaining components, the simplest and most natural route is usually the best. Always avoid sharp bends that would kink the tubing!
- The following table contains examples on how to establish connections between the different elements of a cooling circuit based on multiple possible configurations. These are guidelines only, and may change depending on the relative position of the components inside your chassis.

- ❑ From a performance standpoint there is very little performance to be gained from strictly controlling the component sequence: the maximum delta T (difference in temperature) between any two points of the liquid cooling circuit does not exceed 1°C. Whenever possible, performance oriented users will typically want to route the radiator discharge(s) tube(s) to the inlet of the CPU cooler, since the fluid exiting the radiators is always the coolest.

Devices: ❑ (1) CPU cooler + (1) Radiator + Pump-reservoir assembly

- Connect:
- ❑ Pump discharge to radiator inlet
 - ❑ Radiator discharge to CPU cooler inlet
 - ❑ CPU cooler discharge to reservoir inlet
 - ❑ Reservoir discharge to pump inlet – MANDATORY!

Alternatively,

- Connect
- ❑ Pump discharge to CPU cooler inlet
 - ❑ CPU cooler discharge to radiator inlet
 - ❑ Radiator discharge to reservoir inlet
 - ❑ Reservoir discharge to pump inlet – MANDATORY!

Devices ❑ (1) CPU cooler + (1) VGA cooler + (1) Radiator + Pump-reservoir assembly

- Connect:
- ❑ Pump discharge to VGA Cooler inlet
 - ❑ VGA cooler discharge to radiator inlet
 - ❑ Radiator discharge to CPU cooler inlet
 - ❑ CPU cooler discharge to reservoir inlet
 - ❑ Reservoir discharge to pump inlet – MANDATORY!

Alternatively,

- Connect:
- ❑ Pump discharge to CPU cooler inlet
 - ❑ CPU cooler discharge to VGA cooler inlet
 - ❑ VGA cooler discharge to radiator inlet
 - ❑ Radiator discharge to reservoir inlet
 - ❑ Reservoir discharge to pump inlet – MANDATORY!

Devices: ❑ (1) CPU cooler + (1) VGA Cooler + (1) chipset Cooler + (1) Radiator + Pump-reservoir assembly

- Connect:
- ❑ Pump discharge to chipset cooler inlet
 - ❑ Chipset cooler discharge to VGA cooler inlet
 - ❑ VGA cooler discharge to radiator inlet
 - ❑ Radiator discharge to CPU cooler inlet
 - ❑ CPU cooler discharge to reservoir inlet
 - ❑ Reservoir discharge to pump inlet – MANDATORY!

Alternatively,

- Connect:
- ❑ Pump discharge to CPU cooler inlet
 - ❑ CPU cooler discharge to chipset cooler inlet
 - ❑ Chipset cooler discharge to VGA cooler inlet
 - ❑ VGA cooler discharge to radiator inlet
 - ❑ Radiator discharge to reservoir inlet
 - ❑ Reservoir discharge to pump inlet – MANDATORY!

Devices: ❑ Dual CPU cooler and VGA cooler (SLI) configurations

- Connect:
- ❑ CPU coolers in series: CPU cooler (1) discharge to CPU cooler (2) inlet
 - ❑ VGA coolers in series: VGA cooler (1) discharge to VGA cooler (2) inlet

Devices: ❑ Dual Radiators: A second radiator can be added anywhere in the loop in series with the other components, for example

- Connect
- ❑ Pump discharge to radiator (1) inlet
 - ❑ Radiator (1) discharge to VGA cooler inlet
 - ❑ VGA Cooler discharge to chipset cooler inlet
 - ❑ Chipset cooler discharge to radiator (2) inlet
 - ❑ Radiator (2) discharge to CPU cooler inlet
 - ❑ CPU cooler discharge to reservoir inlet
 - ❑ Reservoir discharge to pump inlet – MANDATORY!

II. Installation of the cooling components

Warning! Placement of the cooling components may vary depending on your chassis and motherboard configurations. A mock-up installation is thus necessary to estimate the length of the different sections of tubing that will be required between each component.

The following is the recommended sequence of components installation.

1. Radiator and fan
2. Water-block(s)
3. Pump
4. Reservoir

1. MCR220 RADIATOR INSTALLATION

Preamble:

The MCR220™ dual 120mm radiator ships with the fans and the Radbox chassis already pre-assembled to the radiator. It is assumed in effect that users will take advantage of our Radbox concept (external radiator installation) due to the benefits it provides and ease of installation. In such context, the following installation guide describes this type of installation. We also recognize that due to various considerations (cosmetics, space, or simply user preference) a number of users will wish to install the MR220 radiator internally. Because of the large size of the radiator, it is most likely that an internal installation will require extensive modifications in most computer cases. Because these modifications depend on the structure and dimensions of each individual chassis, we simply cannot provide precise installation instructions to this effect. Here are some general guidelines that advanced “case-modders” should take into consideration:

Radiator installation, general considerations:

For optimum performance radiators require an unobstructed source of cool air. This dictates either an external mounting or one on/in the case where the radiator will draw cool air from the exterior. The second consideration is the placement of the inlet and outlet connections; at least one connection should be at the ‘top’ of the radiator to make it self-purging.

An external mounting can be effectuated by means of the RadBox affixed to the backside of the case and the tubing routed through holes drilled in the case underneath the power-supply. This places the connections at the top of the radiator and it will preclude the accumulation of air in the radiator.

Single 120mm fan radiators can be mounted over appropriately sized openings in a variety of cases; conversely, mounting a dual 120mm radiator is considerably more difficult and generally results in placing the radiator ‘inverted’ at the top, or ‘right side up’ at the bottom. Note that the ‘inverted’ mounting places the inlet and outlet facing down; this mounting will accumulate air over time. Placing the radiator ‘right side up’ in the case bottom will make the radiator self-purging, but it will gather dust VERY quickly if adjacent to the floor. In many situations, mounting a dual 120mm radiator inside a case will require extensive modifications for the air inlet and mounting of the radiator; it should be noted that case manufacturer growing awareness for water-cooling fosters the release of “liquid-cooling ready” solutions that will greatly facilitate the installation of this kit. There is no standard in this respect, and therefore no “formula” for installation; as a result users will simply need to exercise common sense and good judgment.

□ General concept schematic

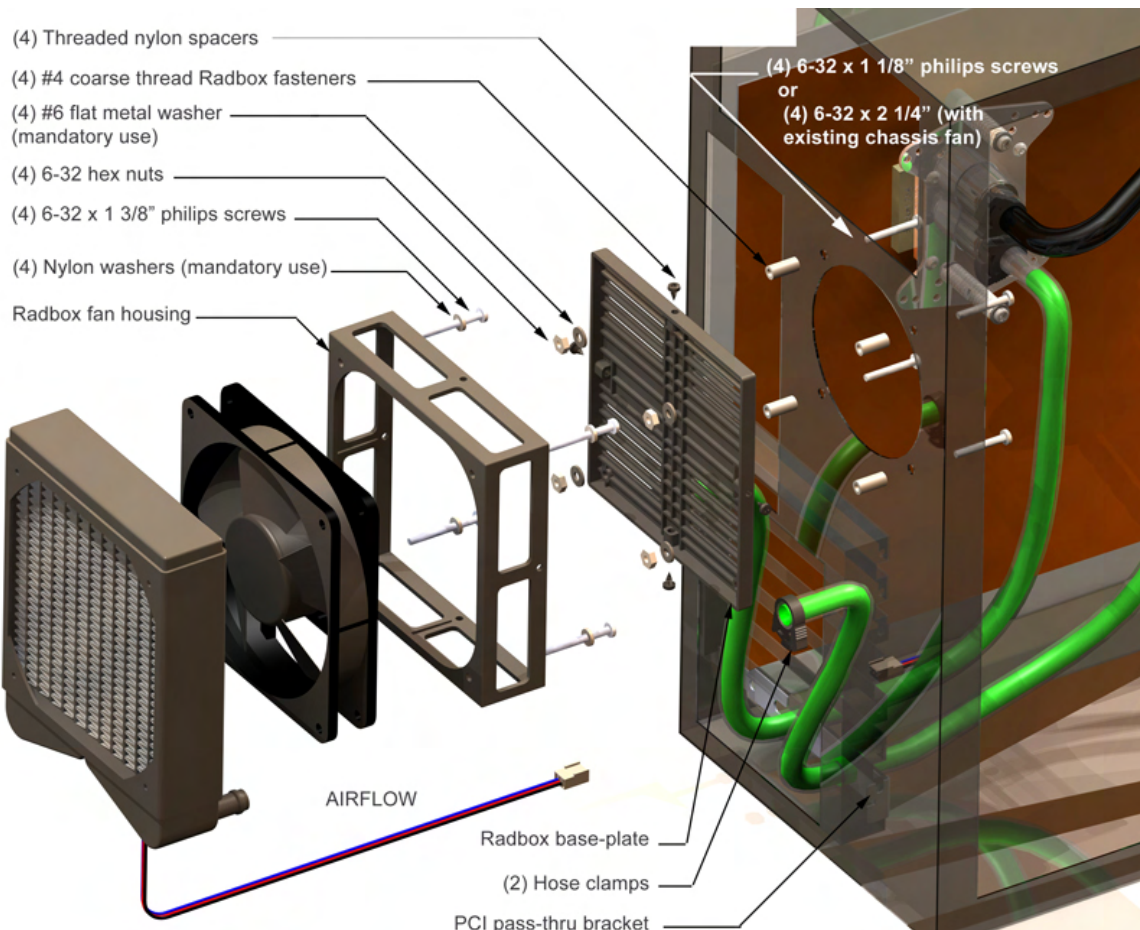

□ **Installation**

- Place the radiator assembly on the back of the computer to roughly estimate where it will fit best.
- You need to consider the following clearance issues:
 - Exit cables and connectors from various PCI devices: the Radbox base plate can be moved in both vertical and horizontal directions to allow clearance for the cables
 - Opening the side panel once the Radbox is installed: the Radbox is supplied with various nylon spacers to separate the base plate from the surface of the back-panel and to provide clearance for opening of the side-panel.
 - Note that a chassis with 80mm fan opening(s) is likely to provide a very good range of adjustments. Conversely, a chassis featuring a single 120mm fan opening the base-plate is a direct bolt on, but offers no adjustments, which may or may not suit our installation for the purpose of positioning the radiator. In that case, it will become necessary to drill (4) mounting holes of 0.150" (~3.5mm) in diameter to install the base plate at the desired location.
- Securing the base plate at the desired location.

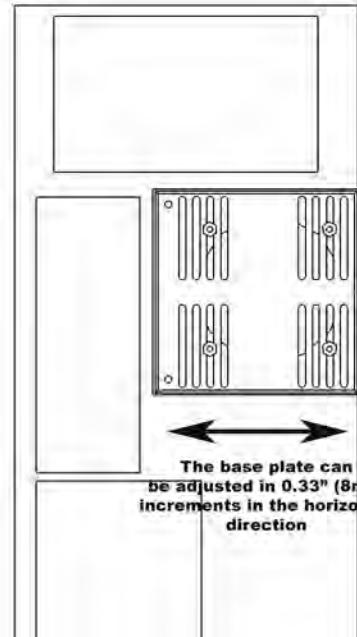
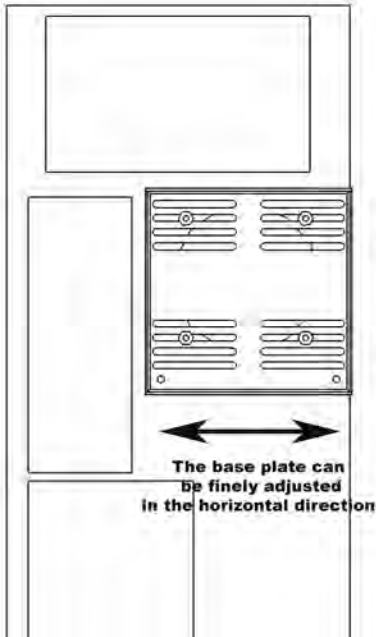

- Once satisfied with the position, bolt down the Radbox back-plate with the provided nylon nuts.
- Next, you will need to mark the location of the holes that must be drilled to allow routing of the tubes through the computer back-panel. You can cut two small pieces of the provided PVC tubing and install these to the radiator hose barbs, then temporarily mount the radiator assembly onto the back-plate. The tubing will provide a convenient way to mark the position of the holes as shown below:

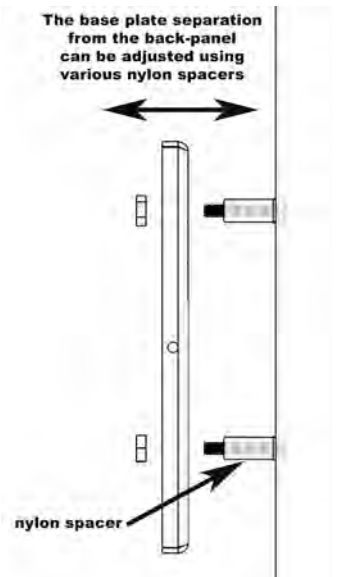

- Once the two holes are cut, de-burr the edges, and install the grommets.
- Install your radiator assembly onto the back plate.

Once the tubes are connected to the radiator, the final results will look like so:

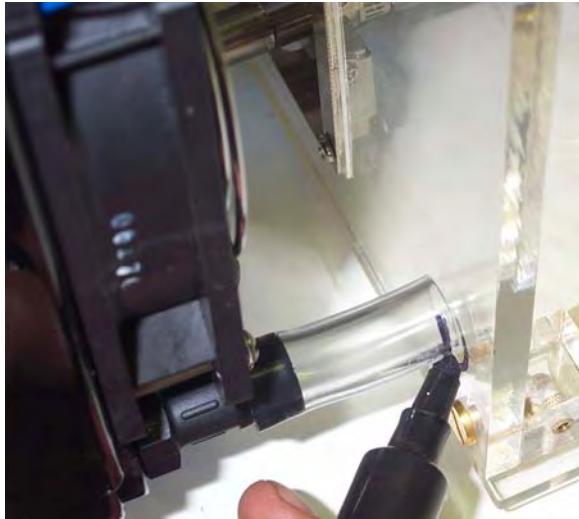

- Remove the radiator assembly from the back-plate and mark the center of the circle.
- Two rubber grommets are provided with your kit so that you can route the tube through the case without damaging the tubing with the sharp edges of the hole. The required hole diameter for the grommet is 7/8" (23mm).
- To cut the holes, use a heavy-duty Bimetal hole saw of 7/8" in diameter:



- Finally, you need to route the fan wires through the back-panel. This can be done easily with the provided PCI adapter plate featuring a hole and grommet for protection of the wire.



2. APOGEE GTZ WATER-BLOCK INSTALLATION

- Installation with Intel® socket 775, Core™ 2, Core Duo, Extreme (default water-block configuration)



1. Install the back-plate

Peel of the protective paper and apply the back-plate to the back of the motherboard by firmly pressing its center.



2. Prepare the CPU

Clean the CPU with a degreaser (preferably formulated for electronics) then apply the supplied grease to the center of the CPU.

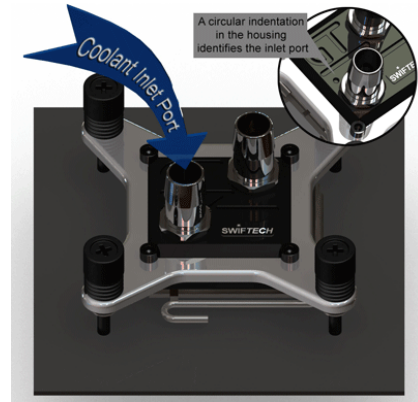
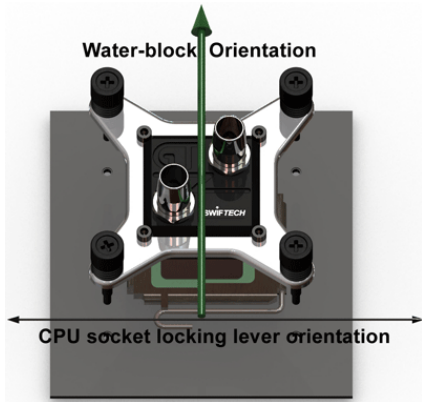

3. Fasten the block to the motherboard

For optimal performance, it is critical to orient the water-block properly relative to the socket. As illustrated above, the waterblock North-South axis should always be perpendicular to the socket locking lever.

Once oriented, progressively and alternatively (in a cross pattern) fasten the 4 screws until they bottom out.

4. Install the tubing

You should first positively identify the flow direction in your cooling system. The coolant should enter the water-block inlet port which is identified by a circular indentation in the housing next to it.

Last, fasten the tubing with the provided hose-clamps. The installation is now complete!

- ❑ Installation with Intel® socket 1366, Core™ i7 Desktop Solutions - Removal of the default hold-down plate required.

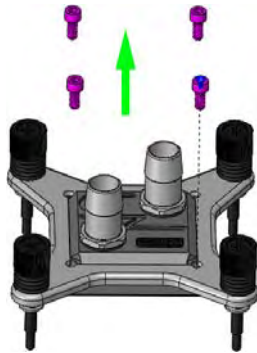

Figure 1

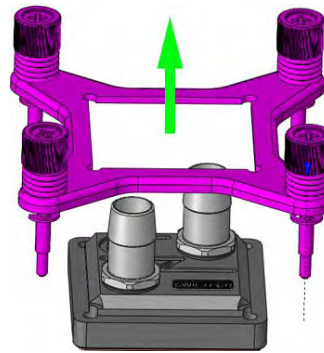

Figure 2



Figure 3

Loosen & remove the 4 socket head screws using the allen wrench provided with your Apogee™ GTZ

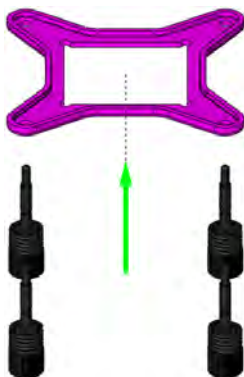

Figure 4

Lift the hold-down plate screw-spring assembly, and set the Apogee™ GTZ aside

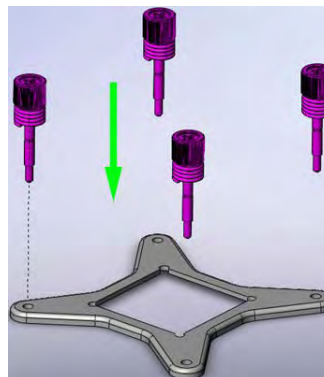

Figure 5

Slightly press down on the plate and remove the clips with long nose pliers

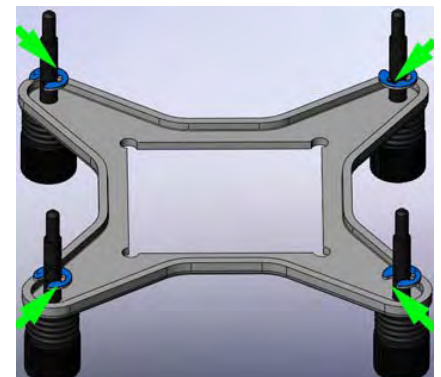

Figure 6

Remove and set aside the socket 775 hold-down plate

Place the existing screw-spring assemblies into the socket 1366 hold-down plate mounting holes

Slightly press down on the plate and install all 4 clips with long nose pliers

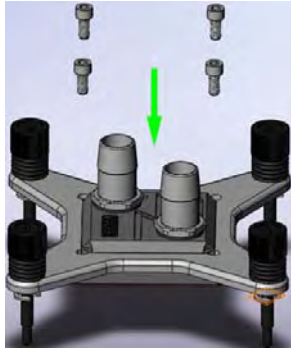

Figure 7

Fasten the hold-down plate assembly to the Apogee™ GTZ water-block

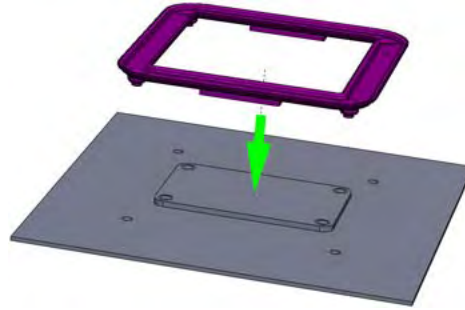

Figure 8

Peel-off the protective paper from all four foam strips, and apply the back-plate against the back of the motherboard. Perfect centering can be achieved by slightly pushing one of the plate standoffs into a motherboard hole, then by squaring off the plate with the opposite hole.

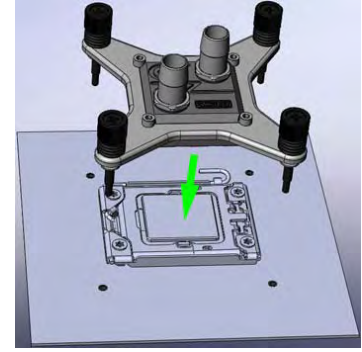

Figure 9

Apply thermal grease to the CPU, then fasten the Apogee™ GTZ to the motherboard by gradually tightening all four screws in a cross pattern until they bottom out.

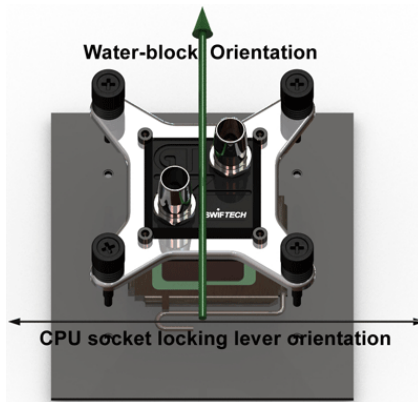

Figure 10

As with socket 775, and for optimal performance it is critical to orient the water-block properly relative to the socket. As illustrated above, the waterblock North-South axis should always be perpendicular to the socket locking lever, irrespective of the socket orientation relative to the motherboard.

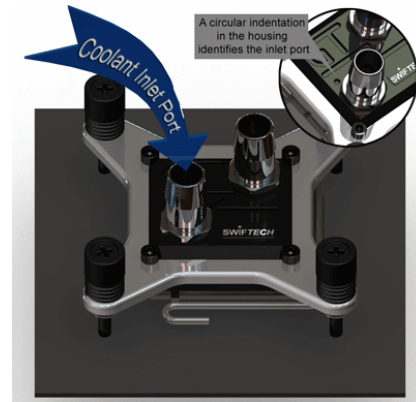

Figure 11

When you are ready to install the tubing, you should first positively identify the flow direction in your cooling system. The coolant should enter the water-block inlet port which is identified by a circular indentation in the housing next to it.

❑ Installation with Intel® socket 1366 (Core™ i7) Server Solutions.

The Apogee GTZ socket 1366 hold down plate is fully compatible with Intel® socket 1366 (Core™ i7) server platforms and complies with Intel specifications for server motherboards shipped with a Unified Retention System (URS). The Apogee GTZ simply bolts onto the existing URS back-plate.

❑ Installation with Intel® legacy server platforms (socket 771, Xeon)

Please contact Swiftech Customer service for your free back-plate (see terms and conditions page 2)

❑ Installation with AMD® socket 754, 939, F and AM2

Please contact Swiftech Customer service for your free back-plate (see terms and conditions page 2)

3. MCW30 CHIPSET WATER-BLOCK INSTALLATION

Please refer to the separate installation guide included with the MCW30 water-block.

4. MCW60 VGA WATER-BLOCK INSTALLATION

Please refer to the separate installation guide included with the MCW60 water-block.

5. RE-INSTALLING THE MOTHERBOARD

Once your water-blocks are securely fastened to the motherboard, go-ahead and install the motherboard back into the chassis, following the instructions provided in your motherboard installation guide.

6. PUMP INSTALLATION

General Use

The MCP655-B pump is a magnetically driven centrifugal pump featuring a 12 V DC motor. It requires no maintenance when used with de-mineralized water and the appropriate anti-fungal additives. We recommend using 5% Swiftech's HydrX™ as an additive. The pump is designed to be connected to your computer power supply using the standard Molex 4 pin connectors. A second 3-pin connector (single blue wire) is an RPM sensor designed to be connected to the motherboard in lieu of the CPU fan connector and the motherboard to read the pump speed.

The MCP655-B pump is neither submersible, nor self-priming. The inlet needs to be continuously supplied with fluid for the pump to operate properly.

Physical installation

- Determine the best location for your pump by observing how the tubing will be routed to the rest of the circuit. Sharp bends in the tubing should always be avoided to prevent kinks, which will reduce or completely prevent flow of the cooling fluid.
- In general, we recommend installation of the pump at the bottom of the chassis.
- The base of the pump features a soft neoprene pad coated with **strong** adhesive material. Once the final location for the pump has been determined, simply peel-off the pad's protective paper, and press the pump against the chassis surface. The surface should be clean, and non greasy. Thru-bolts are also provided for permanent installation, and require drilling holes in the chassis.

Pump operating precautions:

The MCP655-B pump should never be run dry, even for a quick test. You should always prime the pump with fluid before you start operating it (see warranty note *).

Use of coloring die or fluorescent additives containing particulate fillers will cause excessive wear to the pump's impeller bearing (see warranty note **).

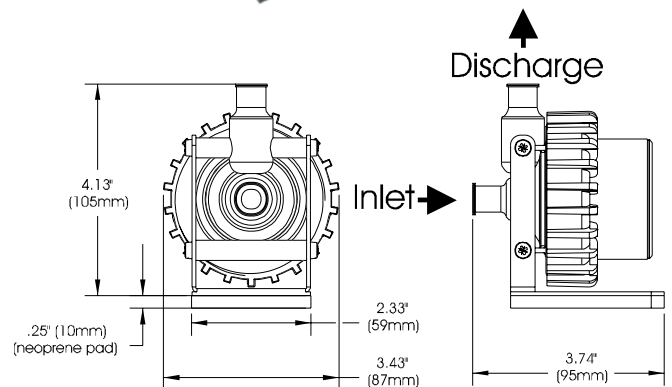
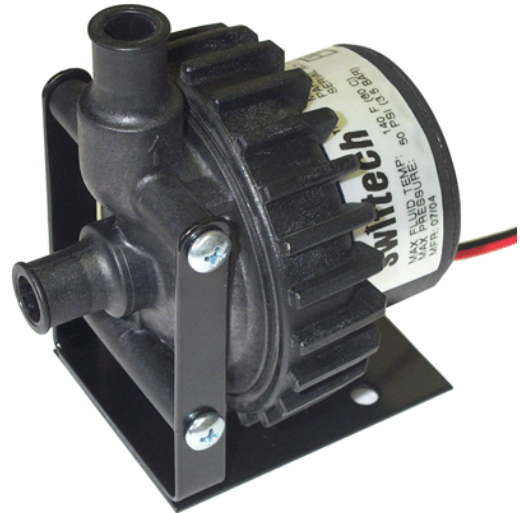

Note 1: Always make sure to directly connect the RESERVOIR DISCHARGE to the PUMP INLET.

Note 2: Please read important preamble in paragraph 6 below "Preparing the Tubing" prior to installing the tubing to your pump.

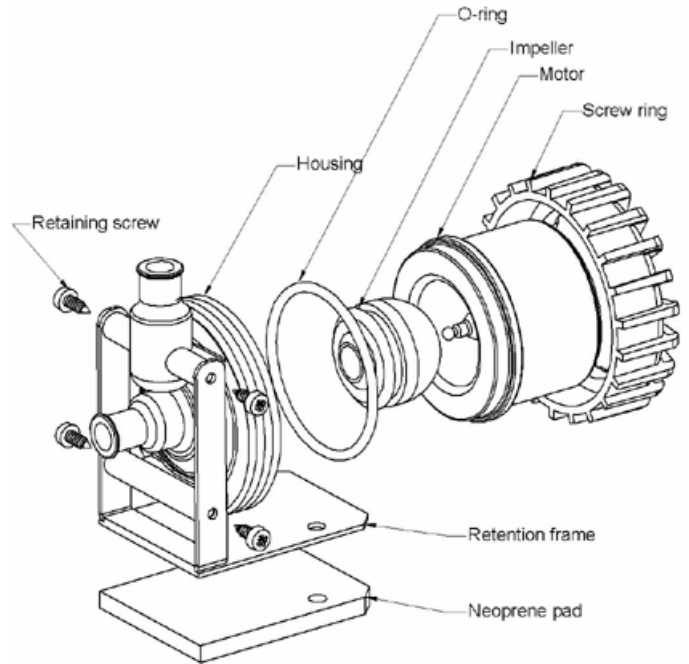
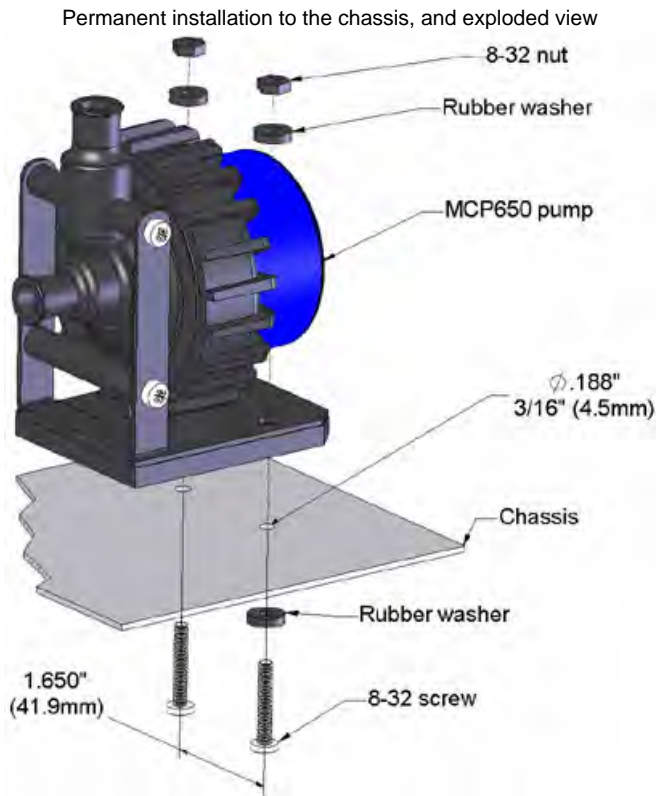

Nominal voltage / Connector	12 V DC / Molex 4 pin	Maximum pressure	50 PSI (3.5 BAR)
Operating voltage range	8 to 24 VDC	Maximum head	10 ft (3.1 m)
Nominal current (@ 12 V)	2 amps	Maximum discharge	~ 317 GPH (1200 LPH)
Nominal power (@ 12 V)	24 W	Temperature range	32 °F to 140°F (0 °C to 60 °C)
Motor type	Brushless, microprocessor controlled	Weight	1.4 LB (650 gr.)
Impeller Housing material	Noryl®	Connection size	½" barbs

7. MCRES-MICRO RESERVOIR INSTALLATION

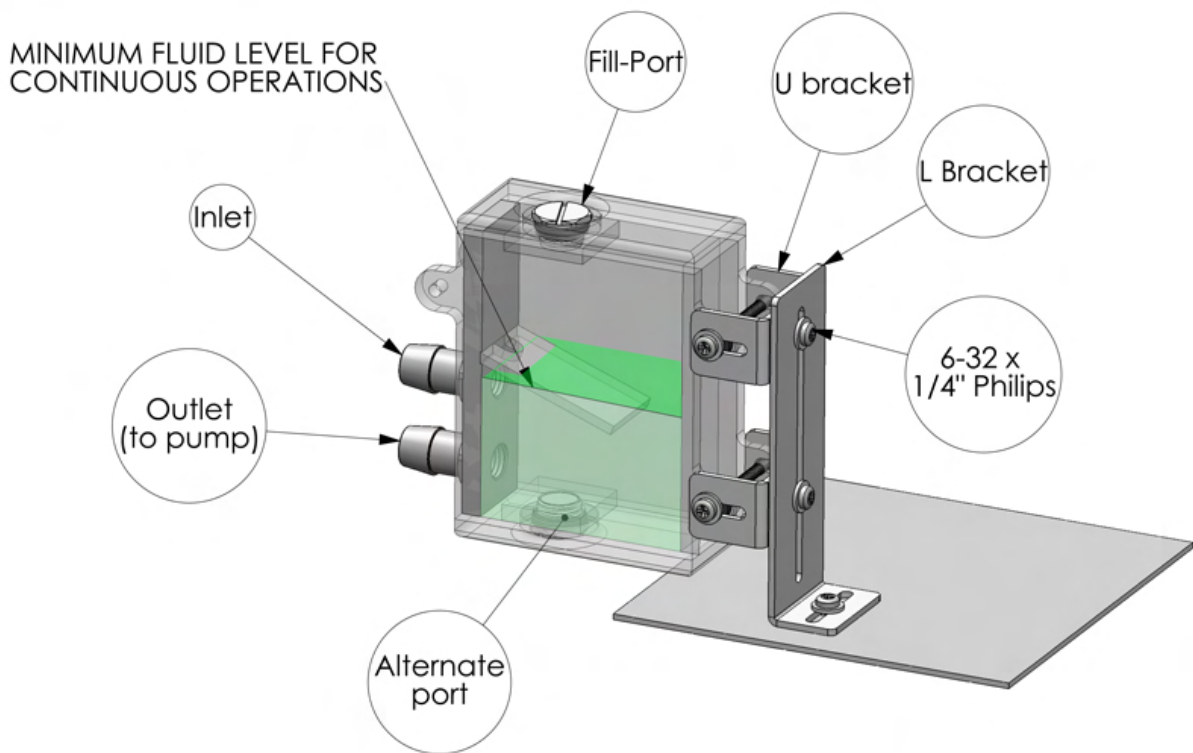

Figure 1

Port Usage definition

Upper side port: "Inlet" as shown in figure 1 is the return line from the system

Lower side port: "Outlet (to pump)" shown in figure 1 should always be connected to the pump inlet (directly if possible to facilitate filling of the system)

The fill-port located on top of the unit is used to fill it up with coolant, and sealed with a chrome plated brass plug.

The alternate port is also sealed with a chrome plated brass plug, and can be used as:

- An alternate outlet providing a straight tube routing to a pump located underneath
- To feed a second pump
- To plug-in a temperature sensor
- A drain

□ Installation

The MCRES-MICRO can be installed in any suitable location meeting its form factor requirements. For filling purposes, it is preferable to install the MCRES-MICRO at the highest point of the liquid cooling loop. However, once filled and hermetically closed, the reservoir can be installed practically anywhere as long as it is kept upright as shown in figure 1. Also, to facilitate the filling and bleeding operations, you might want to wait until the circuit has been filled-up before you fasten the reservoir permanently to the chassis.

Fastening the device to the case: two mounting methods can be used

Various permanent mounts thru the reservoir ears or with the provided mounting hardware as shown page 3.

Easy mount, with the provided Velcro strips. Please note that a permanent mount is recommended for a reliable fastening of the device over time.

MCRes Micro Bracketry installation and examples

ITEM NO.	PART NUMBER	DESCRIPTION	QTY
1	BCKT1	"L" bracket	1
2	BCKT2	"U" bracket	2
3	90272A146-6-32x3-8-philips	6-32 x 3/8" Philips screw	3
4	91772A158-6-32X1.75	6-32 x 1 3/4" Philips screw	2
5	90760A007	6-32 Nut w/teeth washer	3
6	FW150X437X092	Rubber Washer 437X150X092	2
7	93286A041-WASHER	zinc plated washer	5

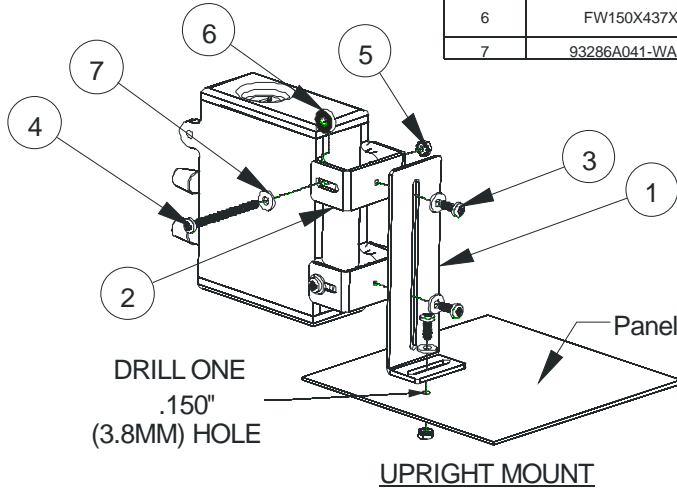

Note 1: rubber washer 6 should be inserted between either side of the reservoir ear and the U bracket 2.

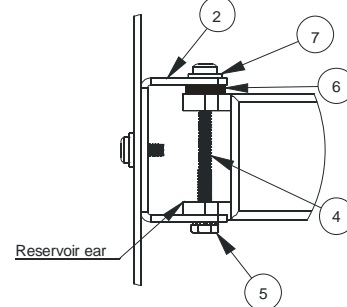

HANGING MOUNT

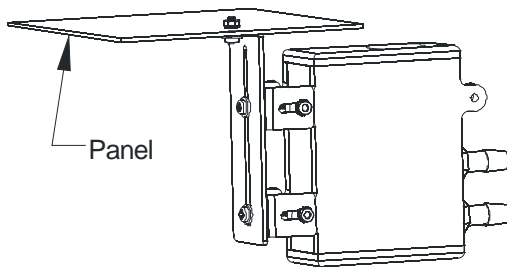

BACK-PANEL MOUNT

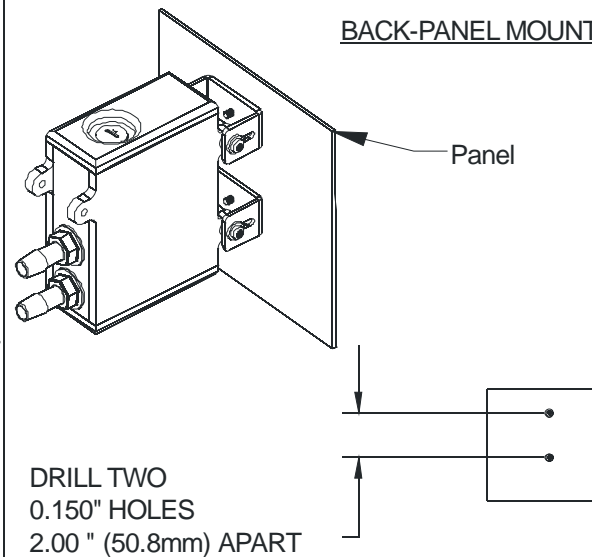

Note 2: the 6-32 x 1 3/4" screw #4 & nut #5 assembly is designed to protrude as little as possible in order to reduce overall clearance necessary for the Micro Res assembly. It is thus necessary to slightly push the nut in order to engage it on the screw thread.

❑ Preparing the coolant

- Your kit comes with a 2 Oz (60ml) bottle of Swiftech's specially formulated HydrX™ concentrated coolant. The product should be mixed with distilled water only. Simply empty the concentrated coolant into a 33 fl oz (1 liter) plastic bottle, and complete filling with distilled water. Your coolant is now ready. Note: a 5% mix might still allow some algae formation over prolonged usage if your system is continuously exposed to daylight (such as a clear acrylic case for example). Under such circumstances, we would suggest using a 10% mix.
- Use of alcohols (Alcohol Allyl, Amyl, Benzyl, Ethyl (Ethanol), Isopropyl, Methyl (Methanol), n-Butyl) or antifreeze products containing the listed alcohols is prohibited as it will result in deterioration of the reservoir over-time, and will void your warranty.** Resistance to Ethylene and Methylene glycol used in antifreeze products is excellent.
- Minimum Operating Level** is situated at the Swiftech Logo (approximately 1/2" of the reservoir). The reservoir should not be operated below this level, which could result in degradation of the system cooling.

8. INSTALLING THE TUBING

Preamble:

Your kit comes with 7/16" ID (5/8" OD) tubing. This type of tubing was specifically selected following suggestions made by our enthusiast users because it offers very low flow restriction, similar to that of true 1/2" ID tubing, without the bulk of true 1/2" (which is 3/4" OD and therefore hard to work with). This tubing will fit easily onto standard 1/2" barbs EXCEPT for the MCP655-B pump. In effect, the design of the hose barbs on this pump makes it quite difficult to install this slightly smaller tubing. Two things can be done to ease this process:

- Rub the pump barbs with liquid soap to make them slippery
- Soften-up the extremity of the tubes by dipping them in a glass of boiling water for about 20 to 30 seconds (boil some water in a microwave oven, then dip the extremity of the tube).

Then work the tube around the pump hose barbs by pushing it firmly. Be patient, it is not easy but it does work.

Smartcoils and tubing installation

Now that your radiator, water-block, pump and reservoir are in place, it is time to cut segments of tubing and connect the devices together.

Your kit comes with a 40" length of Smartcoils which, when extended is a sufficient length to cover 6 feet of tubing. Use of these coils is recommended whenever there is a sharp bending radius in order to prevent kinking and flattening of the tube over time.

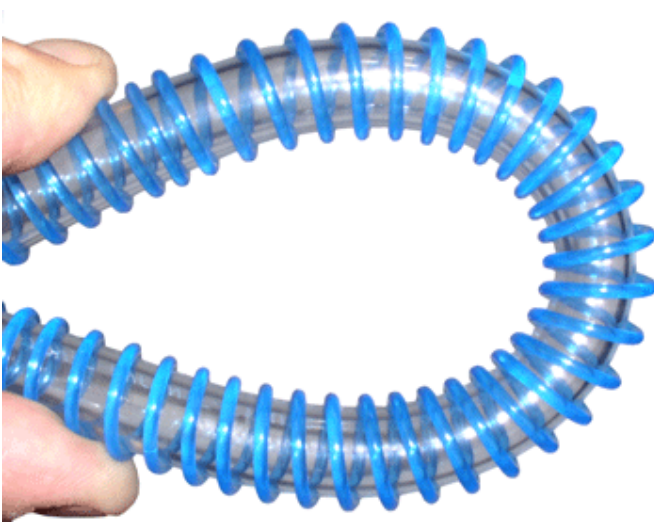

Example of wrapping for a tight bend. (Shown with the blue version for picture clarity – The kit actually comes with clear coils).

Wrap the Smartcoils around the tubing

Gather the Smartcoils towards the center of the tubing, and then pull on the ends of the tubing. This will allow the coils to expand to their natural pitch.

Another technique to evenly spread the coils along the tubing consists in pushing one of the extremities of the coil clockwise. This will loosen the coils from around the tube, and allow you to spread them easily.

Tight radii sections require that coils be close to each other (1/8" spacing coil to coil). In straight sections, coils can be spaced up to 1/4" or more, coil-to-coil.

- ❑ Then, with one end of a tube connected to a startup component such as the water-block for example, roughly estimate the length that you will need to the next component, and cut the tube and coil squarely with a pair of scissors. Work your way through the entire circuit in the same fashion, until you are satisfied with the tube routing.
- ❑ Secure all the connections of tube to hose barbs with the provided hose-clamps:



9. COMPLETING THE INSTALLATION

- ❑ **Re-installing your power-supply**

- Prior to fill-up the circuit, you will need to re-install your power-supply in order to start-up the pump during the fill procedure. You must be able to start the PSU without it being connected to the motherboard. While the Internet contains numerous references on how to use a paper-clip to short-out pin 13 and 14 of the 20 pin ATX connector as shown below, we nonetheless recommend instead using a power-supply tester. A wide variety of these common devices are available on the Internet (**Google** key word: "PSU tester"), and among Swiftech resellers (www.frozencpu.com, www.Directron.com, www.newegg.com, etc.).

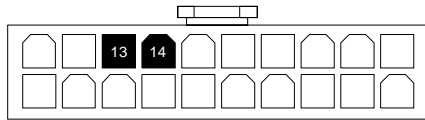

□ Filling-up the circuit

- Simply pour the coolant that you prepared into the reservoir – **carefully to avoid spills**, allowing the circuit to fill-up by simple gravity. Note: for the gravity to take effect the reservoir should be placed or held at the highest point of the cooling circuit. Once the reservoir is full, seal the fill port back with its cap in order to avoid any spills, and start-up the pump. The reservoir will quickly (within 1 second) empty itself. Immediately turn off the pump, top-off the fluid to the maximum level, and restart the pump. You need to repeat this operation 2 to 3 times, until the circuit is finally full of coolant. Then, allow the system to run 10 minutes uninterrupted to clear all the micro-bubbles and foam, and finally top-off the level one last time. Your liquid cooling circuit is now ready, and you may permanently install the reservoir.
- **Allow the system to run for (3) hours and frequently inspect all your connections for possible leaks before you reconnect and re-install all your components (motherboard, hard drives, etc.)**

CONGRATULATIONS, YOUR INSTALLATION IS NOW COMPLETE!



Example of installation

10. TROUBLESHOOTING

- ❖ ***Air keeps circulating into the circuit, long after the pump has primed:***
 - There is a significant pocket of air trapped into the circuit. In most cases this will be due to the fact that the radiator and or the water-block where installed upside down. Temporarily dismount the device and re-orient right side-up until all the air has escaped back into the circuit.
 - The fluid level is too low: top-off the reservoir to the appropriate level.
 - One of the components connections is loose, or improperly tightened: Inspect each connection for traces of moisture, and tighten all worm-drive clamps, and various connections in the circuit.

- ❖ ***The pump does not prime.***

It is likely that the circuit is not installed correctly. Please check that the reservoir discharge is duly connected to the pump inlet. Reminder: do not let the pump run dry.

- ❖ ***The Coolant is filled with debris of some sort:***

Despite our best efforts, such as lengthy ultrasonic cleaning of the radiator, and careful inspection and cleaning of all the parts we manufacture, it is always possible that debris or some sort may be contaminating your circuit. When this happens it will significantly affect the performance of the APOGEE water-block, which mini-jets can be easily obstructed due to their small size. The circuit should then be completely flushed (see draining procedure below), and the APOGEE water-block should be disassembled for inspection and cleaning.

11. DRAINING THE SYSTEM

- Open up the fill-cap from the MCRES-Micro
- Then, you will need to disconnect a line from one of the lowermost components. Typically, this would be the pump. You need to procure a bucket large enough to receive approximately 1 liter of fluid, and place the bucket underneath the connection that you intend to “break”. Disconnect the line, and place both ends into the bucket, until all the liquid is drained from the system.

12. PERIODIC MAINTENANCE

- Every 6 months: dust off the radiator fins and fan. You can use a can of compressed air for example, available in most electronic supply stores. If you live in a very dusty area, you should perform this task at closer intervals. It is essential to maintain the optimum performance of your cooling system.
- Inspect the liquid level inside the reservoir, and refill if necessary (no refills are normally necessary for 18 months of continuous usage). Evaporation in this closed circuit is extremely limited, but still present due to some permeability in the vinyl lines.

13. OPTIONAL COMPONENTS

Please visit our web site at www.swiftech.com on a regular basis, as we continuously release new products that could enhance the use of your H20-220 Apex Ultima liquid cooling kit!

Thank you for trusting Swiftech® for your computer-cooling needs!