

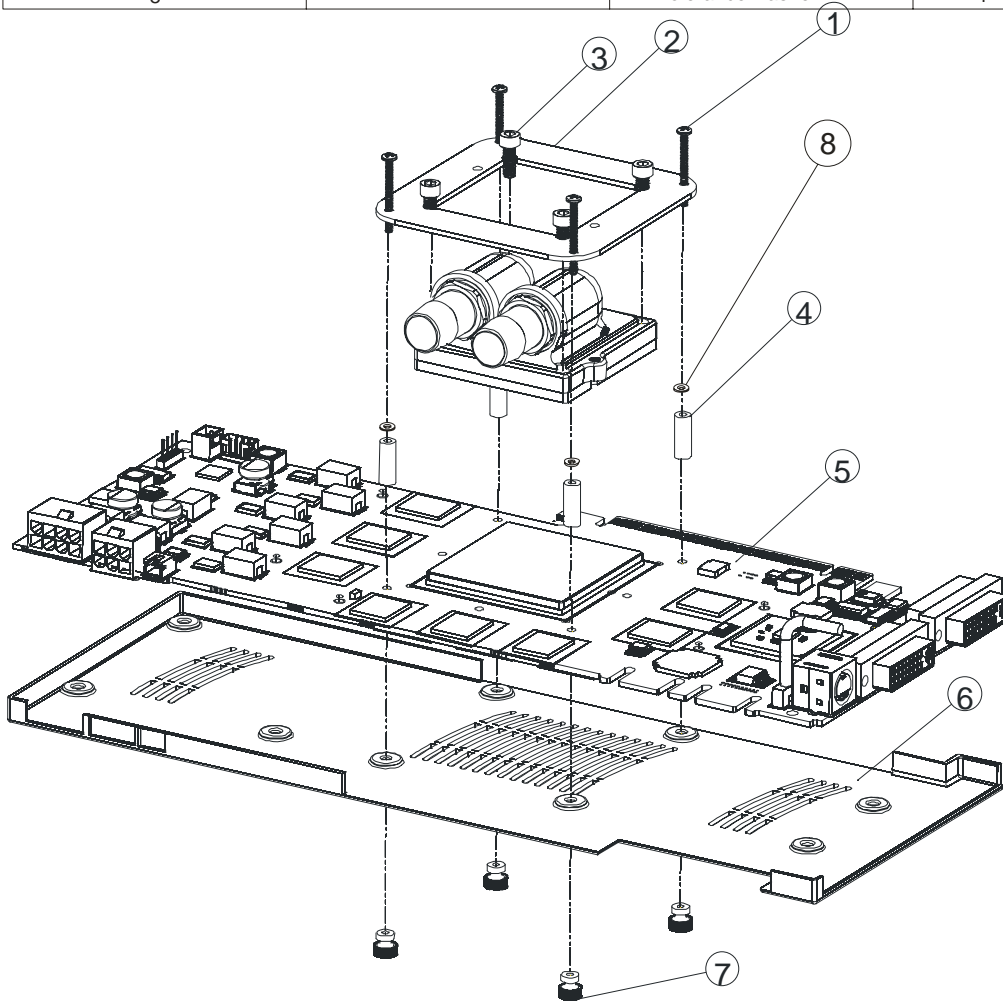

GT200 Adapter plate for MCW60 Installation Guide

| Item # | Part # | Description | Quantity |
|--------|-------------------|---------------------|----------|
| 1 | 2-56x7/8" Philips | Screw | 4 |
| 2 | MCW60-GT200 HDP | Hold-down Plate | 1 |
| 3 | 6-32x3/8 socket | Screws | n/a |
| 4 | 15TSB056B | Tapped nylon spacer | 4 |
| 5 | GT200 VGA | Graphics Card | n/a |
| 6 | GT200 VGA | Back plate | n/a |
| 7 | 77706 | 2-56 Thumb nut | 4 |
| 8 | | Tolerance washer | 4 |



1. Remove the existing hold-down plate from the MCW60 by loosening the (4) socket screws #3, and replace it with the provided GT200 adapter plate.
2. Insert the (4) provided Philips screws #1 into the mounting holes of the hold-down plate, and fasten them to the plate with the (4) provided threaded nylon spacers #4
3. Clean the GPU surface from old thermal compound with alcohol or an electronics degreaser, and apply the equivalent of a little mound of the provided Arctic Céramique Thermal compound



4. Place the MCW60 onto the CPU, the stock back-plate to the back of the card, and tighten all (4) thumb nuts #7 incrementally and in a cross pattern.

The installation is finished. Always test your components for leaks prior to powering-up the motherboard.

Acceptable alternative installations:

1. Using the original back-plate is optional
2. Reversed posts installation: you may install the (4) Philips screws #1 to the back and thru the VGA card, fasten them to the card with the (4) threaded nylon spacers #4, then place the MCW60 onto these posts, and secure with the thumb nuts #7.

DISCLAIMER: While all efforts have been made to provide the most comprehensive tutorial possible, Swiftech® assumes no liability expressed or implied for any damage(s) occurring to your components as a result of using Swiftech® cooling products, either due to mistake or omission on our part in the above instructions, or due to failure or defect in the Swiftech® cooling products. In addition, Swiftech™ assumes no liability, expressed or implied, for the use of this product, and more specifically for any, and all damages caused by the use of this product to any other device in a personal computer, whether due to product failure, leak, and electrical short, and or electro-magnetic emissions. **WARRANTY:** Our products are guaranteed for 12 months from the date of delivery to the final user against defects in materials or workmanship. During this period, they will be repaired or have parts replaced provided that: (I) the product is returned to the agent from which it was purchased; (II) the product has been purchased by the end user and not used for hire purposes; (III) the product has not been misused, handled carelessly, or other than in accordance with any instructions provided with respect to its use. This guarantee does not confer rights other than those expressly set out above and does not cover any claims for consequential loss or damage. This guarantee is offered as an extra benefit and does not affect your statutory rights as a consumer.