

# MCP650™ Installation guide

## 1. General Use

The MCP650 pump is a magnetically driven centrifugal pump featuring a 12 V DC motor. It requires no maintenance when used with demineralized water and the appropriate anti-fungal additives. We recommend using 5% Swiftech's HydrX™ as an additive. The pump is designed to be connected to your computer power supply using the standard Molex 4 pin connectors. The MCP650 pump is not submersible.

## 2. Physical installation

- ❑ Determine the best location for your pump by observing how the tubing will be routed to the rest of the circuit. Sharp bends in the tubing should always be avoided to prevent kinks, which will reduce or completely prevent flow of the cooling fluid.
- ❑ In general, we recommend installation of the pump at the bottom of the chassis.
- ❑ The base of the pump features a soft neoprene pad coated with strong adhesive material. Once an appropriate location for the pump has been determined, simply peel-off the pad's protective paper, and press the pump against the chassis surface. The surface should be clean, and non greasy. Thru-bolts are also provided for permanent installation, and require drilling holes in the chassis (see permanent installation page 2).

## 3. Pump operating precautions:

**The MCP650 pump should never be run dry, even for a quick test.** You should always prime the pump with fluid before you start operating it (see warranty note \*).

**Use of coloring die or fluorescent additives** containing particulate fillers will cause excessive wear to the pump's impeller bearing (see warranty note \*\*).

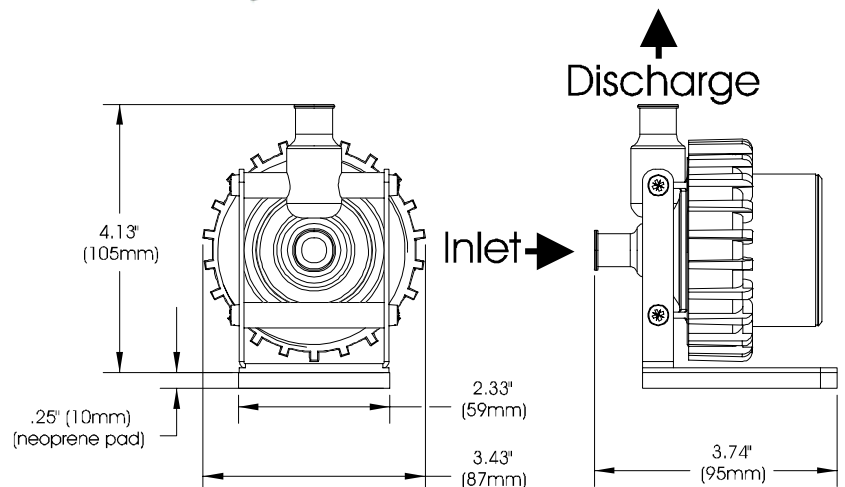
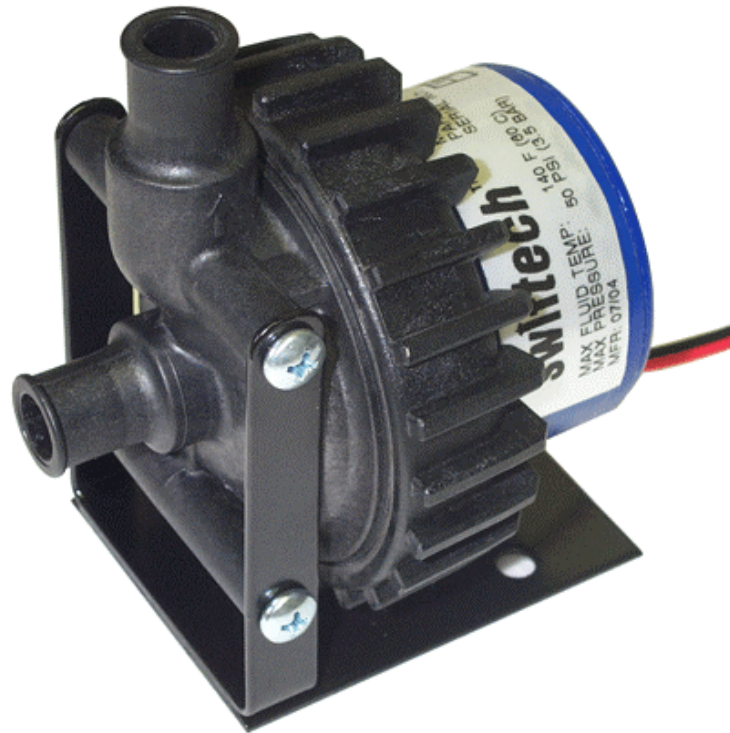

**Do not utilize small diameter or flow restrictive fittings in the pump inlet line. Minimum line inner diameter is 3/8".** An example would be a reservoir with 1/4" fittings. This will cause the pump impeller to cavitate, lose prime, stop pumping and damage the pump (see warranty note \*\*\*).

### Connecting the pump to the circuit:

The pump's inlet and outlet are 1/2" in outside diameter. An optional adapter kit is available to connect the MCP650 to a circuit using 1/2" ODx3/8"ID tubing. This kit consists in: 1 foot supply of 3/4"ODx1/2"ID tubing and two reducers to make the transition to the 1/2"ODx3/8"ID circuit.

**TIP:** when connecting the MCP650 pump to a 1/2"ODx3/8"ID circuit, always use the longest possible 3/4"ODx1/2" tube section at the inlet.



4. Performance & Specifications

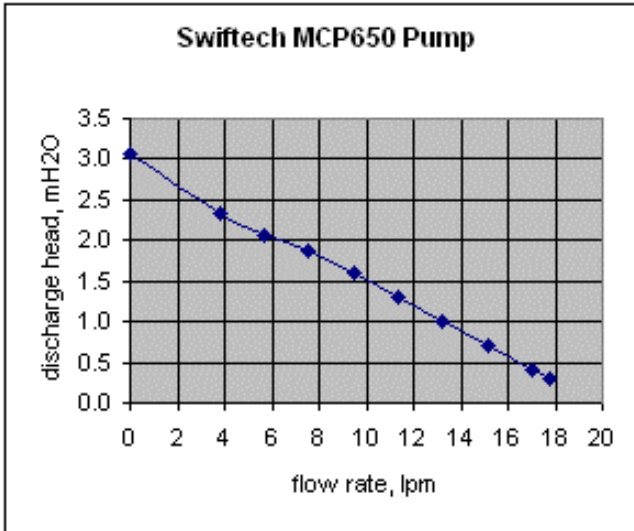

Nominal voltage	12 V DC
Operating voltage range	6 to 14 VDC
Nominal power (@ 12 V)	24 W
Nominal current (@ 12 V)	2 amps
Motor type	Brushless, microprocessor controlled
Maximum head	10 ft (3.1 m)
Maximum discharge	~ 317 GPH (1200 LPH)
Connection size	½" barbs
Maximum pressure	50 PSI (3.5 BAR)
Temperature range	32 °F to 140°F (0 °C to 60 °C)
Electrical connector	Molex 4 pin
Weight	1.4 LB (650 gr.)
Our noise measurement (non lab environment)	33 ~ 34 dBA in a quiet room @ 2'

**WARRANTY:** This product is guaranteed for a period of **24 months** from date of purchase for defects in material, and workmanship. Guarantee consists of replacing defective parts with new or reconditioned parts. Guarantee is considered void in case of **improper use** **(\*)(\*\*)(\*\*\*),** handling or negligence on the part of user. Original invoice showing date and place of purchase is required for exercise of the warranty. **(\*) WARNING: DO NOT ATTEMPT TO RUN THIS PUMP DRY. THIS WILL CAUSE IMMEDIATE AND PERMANENT DAMAGE TO THE PUMP. (\*\*) EXCESSIVE WEAR DUE TO INNAPPROPRIATE FLUIDS. (\*\*\*) EXCESSIVE RESTRICTION TO THE PUMP'S INLET**

**DISCLAIMER:** Swiftech assumes no liability whatsoever, expressed or implied, for the use of this product, and more specifically for any, and all damages caused by the use of this product to any other devices in a personal computer, whether due to product failure, leak, electrical shorts, and or electro-magnetic emissions.

5. Permanent installation to the chassis, and exploded view

