

MCW5000-64™ WATER-BLOCK

INSTALLATION GUIDE FOR ATHLON 64™ PROCESSORS

Parts list

Parts	QTY	PARTS	QTY
MCW5000-64™ assembly	1	Aluminum tension limiter	2
6-32 x 1 ¼ Philips screw	2	Springs	2
Nylon shoulder washers	2	Arctic Alumina Thermal compound	1

This product is intended for expert users. Please consult with a qualified technician for installation. Improper installation may result in damage to your components. Swiftech assumes no liability whatsoever, expressed or implied, for the use of these products, nor their installation. The following instructions are subject to change without notice. Please visit our web site at www.swiftnets.com for updates.

1. **Before you install the MCW5000-64™ water-block:**

a. **Prepare two pieces of tubing** of sufficient length to connect to the rest of your circuit. The cuts must be square as shown in figure 1 or leaks may occur:

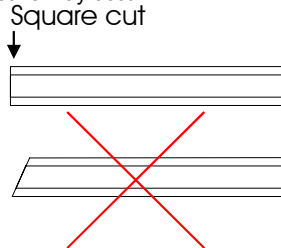

Figure 1

b. **Install the provided plastic tube inserts** at each end of the tubes, as shown in figure 2: these inserts are absolutely **imperative** when using any kind of **soft** tubing, such as vynil, ClearFlex, Taigon, etc...



Figure 2



Figure 3

c. **Spread a little bit of grease or simple liquid soap** around the tubing. It helps pushing the tubes in, particularly with Clearflex™ tubing, which features a very "sticky" surface.



Figure 4



Figure 5

d. **Fully insert both tubes into the fittings.** The tip of the plastic tube inserts should be flush with the inlet and outlet openings, as shown in figure 4 above. Inserting the tubes requires a firm push, accompanied by a twisting motion.

2. **Preparing your Motherboard**

- Remove the existing heat sink
- Carefully clean the CPU.
- Lightly coat the CPU with the provided thermal compound. **Only a paper-thin coat is necessary.** It should be applied using preferably a razor blade, or a credit card, held between thumb and index at a 45-degree angle.

3. **MCW5000-64™ water-block installation diagram**

The MCW5000-64 water-block bolts onto AMD's validated plastic retention frame with two screw spring assemblies. Please use the retention frame provided by your motherboard vendor. Remove the two existing screws that hold the frame in place, place the water-block assembly onto the CPU, and use these two holes to bolt down the spring assemblies, as shown on the schematic (figure 7) page.

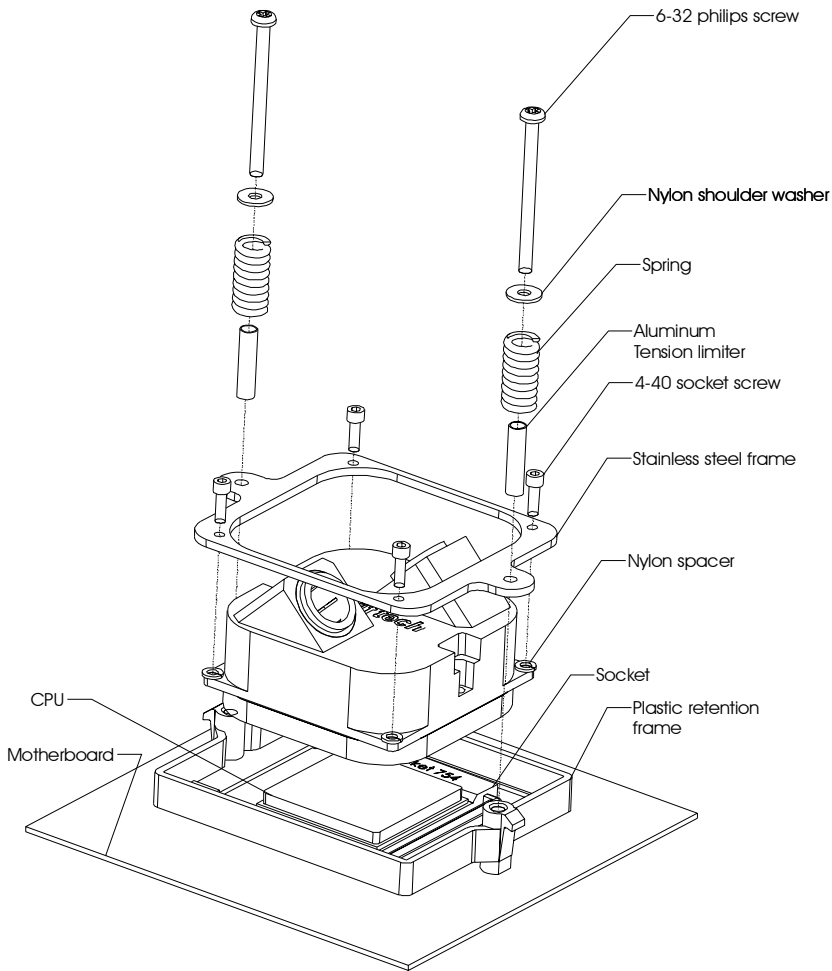
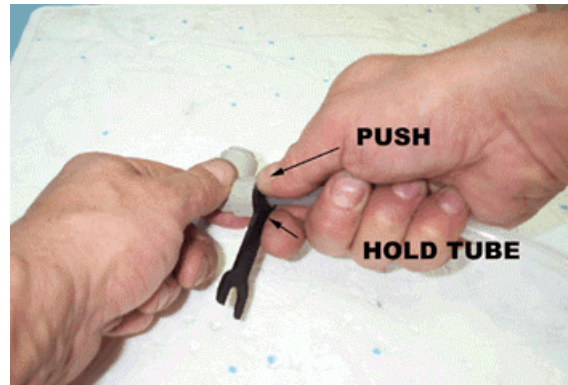
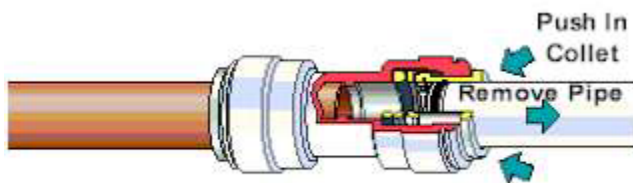

Figure 6

6. Final inspection

Once the installation is completed, it is always a good idea to test the circuit for leaks, prior to powering up the computer. Troubleshooting help is available on our web site at www.swiftnets.com, or by calling customer support at 562-595-8009.

Note concerning removal of the tubing: Push in collet squarely against face of fitting, using swifttech's tube removal tool, or a wrench of approximately the same opening diameter as the tube (1/2" +). With the collet firmly held against the face of the fitting, the tube can be safely pulled out without pushing squarely against the collet. This may result in damaging the fitting.



4. Connecting the water-block(s) to the cooling circuit. FAQs:

- Inlet and outlet are interchangeable.
- In Multi-Processor environments, optimal water-block performance will be achieved by connecting them in series (outlet of one connected to the inlet of the other).

5. Type of Coolant:

- a. For best performance, use 95% distilled water, and 5% Swifttech brand "HydrX" corrosion inhibitor (available here: <http://www.swiftnets.com/store/category.asp?CategoryId=2>, under the "accessories" section).
- b. In ALL cases, you MUST use Distilled water AND a corrosion inhibitor with the MCW5002 water-block. Regular automotive anti-freeze is acceptable. Automotive manufacturers recommend that not less than 25% is used.
- c. NEVER use tap water, even for a short-term test.
- d. Not following paragraphs b and c above constitutes misuse (*) of the product, and will void your warranty.

IMPORTANT DISCLOSURES

While all efforts have been made to provide the most comprehensive tutorial possible, Swifttech assumes no liability expressed or implied for any damage(s) occurring to your components as a result of using Swifttech cooling products, either due to mistake or omission on our part in the above instructions, or due to failure or defect in the Swifttech cooling products.

WARRANTY

Our products are guaranteed for 12 months from the date of delivery to the final user against defects in materials or workmanship. During this period, they will be repaired or have parts replaced provided that: (I) the product is returned to the agent from which it was purchased; (II) the product has been purchased by the end user and not used for hire purposes; (III) the product has not been **misused (*)**, handled carelessly, or other than in accordance with any instructions provided with respect to its use. This guarantee does not confer rights other than those expressly set out above and does not cover any claims for consequential loss or damage. This guarantee is offered as an extra benefit and does not affect your statutory rights as a consumer.