

MCW6000 & 6002 SERIES WATER-BLOCKS INSTALLATION GUIDE FOR XEON™ PROCESSORS

Parts list

| Parts | QTY | PARTS | QTY |
|---------------------------------|-----|------------------------------|-----|
| MCW6000 or 6002-PX™ water-block | 1 | 6-32 x 1 1/4" Philips screws | 4 |
| Worm drive clamps | 2 | Springs | 4 |
| SP4 hold-down plate | 1 | Standoffs | 4 |
| 4-40 Nylon retaining washers | 4 | Black fiber washers | 8 |
| Locknuts | 4 | Céramique thermal compound | 1 |

This product is intended for expert users. Please consult with a qualified technician for installation. Improper installation may result in damage to your components. Swiftech assumes no liability whatsoever, expressed or implied, for the use of these products, nor their installation. The following instructions are subject to change without notice. Please visit our web site at www.swiftnets.com for updates.

The MCW6000 or 6002-PX water-blocks can be installed using two different methods:

- Using the spring-loaded screws and standoffs included with the water-block (fig. 1 below)
- Using the plastic retention frames and spring clips included with most motherboards (fig. 2 page 2)

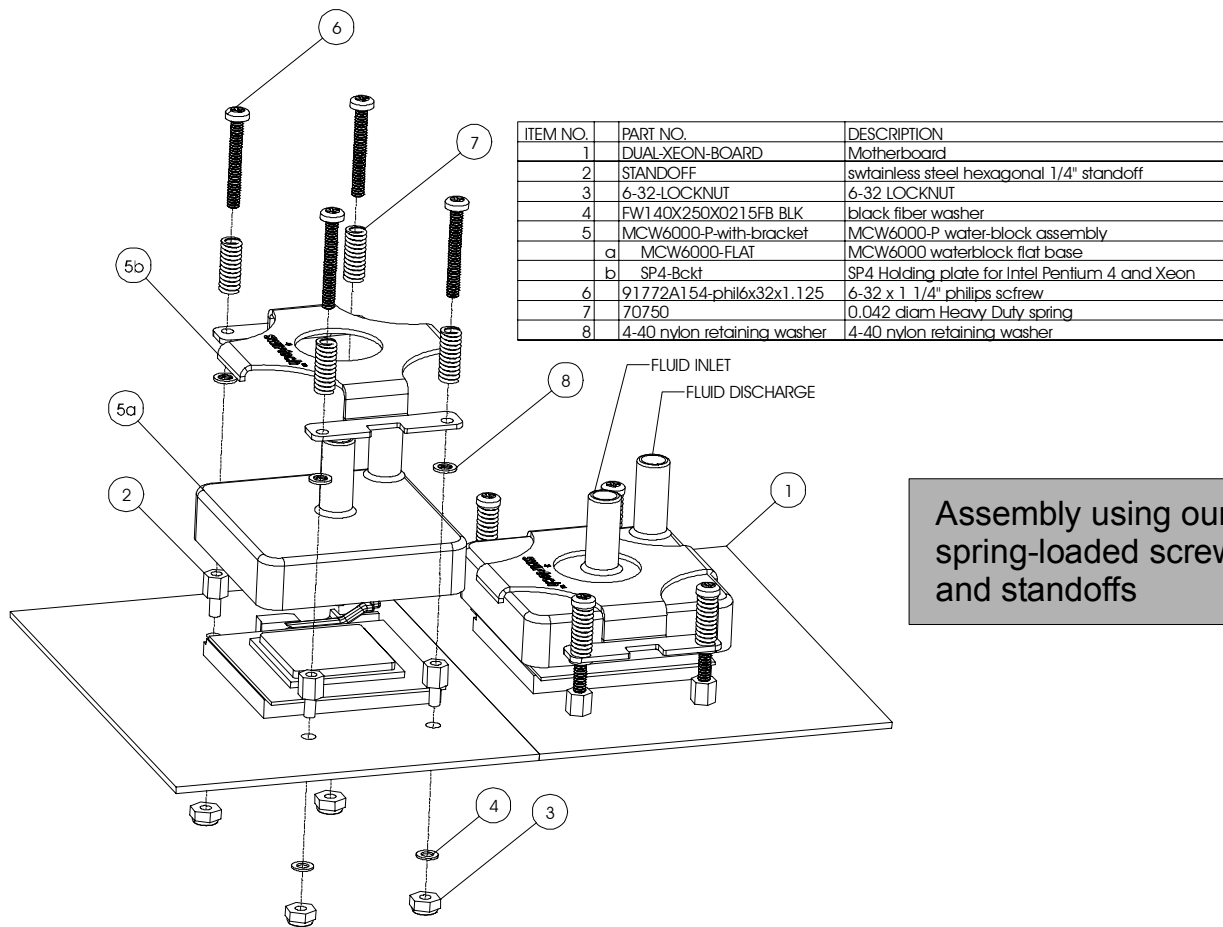

Figure 1

| 16 | PART NO. | DESCRIPTION |
|----|------------------------|--|
| 1 | DUAL-XEON-BOARD | Motherboard |
| 2 | RETENTION | Plastic retention frame, included with motherboard |
| 3 | XEON-CLIP | Xeon clip included with motherboard |
| 4 | MCW6000-P-with-bracket | MCW6000-P water-block assembly |
| | a MCW6000-FLAT | MCW6000 waterblock flat base |
| | b SP4-Bckt | Hold-down plate for Intel Pentium 4 and Xeon |

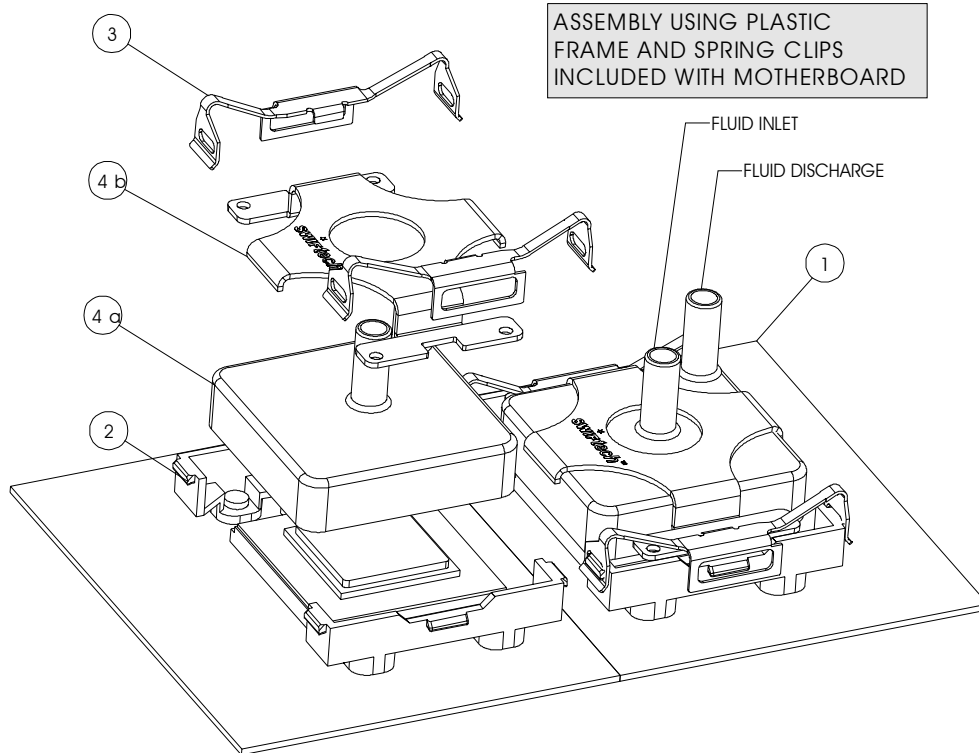

Figure 2

1. **Preparing your Motherboard**

Remove the existing heat sink and carefully clean the CPU
 Apply thermal compound: lightly coat the CPU with the provided Céramique™ thermal compound. Follow this link http://www.arcticsilver.com/ceramique_instructions.htm for detailed instructions.



Rub some compound in base of water-block first, and then clean off with lint-free cloth



Apply small amount of compound on the CPU heat spreader

2. **Waterblock orientation**

For ease of operations during the filling and bleeding procedures, the outlet should always be at the highest point (while the computer system is standing upright):

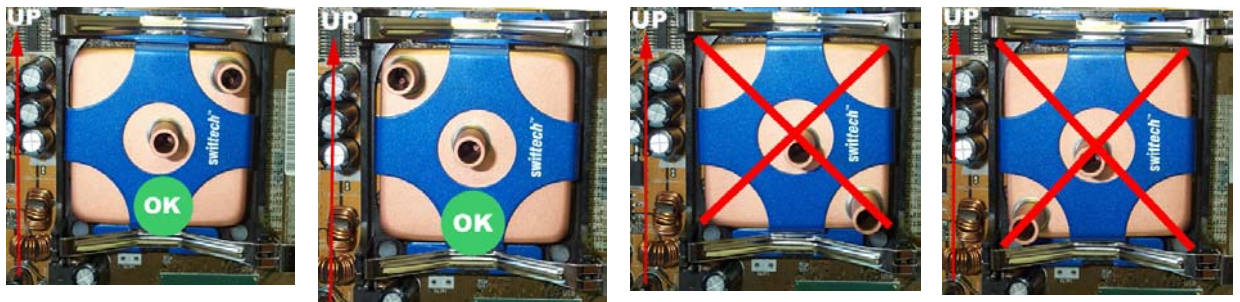

3. Water-block installation

The MCW6000 series can be installed using two different methods (also see figure 1 and 2):

- Using the spring-loaded screws and standoffs included with the water-block (fig. 1), or
- Using the plastic retention frames and spring slips included with most motherboards (fig. 2)

You may use either method at your convenience. For installation with our own spring loaded screws, follow the instructions below. For installation with Intel's spring clips, follow the instructions included in your motherboard manual.

Installation with spring loaded screws:

- Remove the motherboard from the chassis, and remove the stock retention plastic frames to expose the mounting holes.
- Install the standoffs through the holes, using fiber washers and locknuts as shown in figure 1.
- Tighten the standoffs as shown figure 3, using a ¼" socket tool to drive the standoff, and a small pair of pliers to prevent the locknut from spinning. Torque value should not to exceed 16 in. lbs. In other words just tight, without excessive torque, otherwise the standoff stem may snap.
- Tighten the spring-loaded screws in a crisscross pattern until the screws bottom out into the standoff. Once there, do not attempt to lock the screws any further, or they will jam into the standoff, and could prove difficult to remove if you ever need to uninstall the heatsink.

Water-block installation is now complete!

3. Connecting the water-block(s) to the cooling circuit:

Carefully identify the direction of the flow in your circuit. For the MCW6000 to operate properly, the fitting located at the center of the water-block **MUST BE USED AS THE INLET**. In multi-processor environments, connect the two blocks in series: For example: pump discharge to inlet of processor 1, discharge of processor 1 to inlet of processor 2, and discharge of processor 2 to radiator.

4. Attaching the tubes:

The MCW6000™ series ship with worm-drive type hose clamps. Secure the tubes as shown in the picture to the right (shown below with an AMD bracket), and tighten firmly.

5. Type of Coolant:

Being entirely made of copper, the MCW6000™ series may be used with pure water, and do not necessitate the use of anti-corrosion agents. The use of an algicide is nonetheless recommended in any liquid cooling system, and our HydrX™ additive also performs such function.

6. Final inspection

Once the installation is completed, it is always a good idea to test the circuit for leaks, prior to powering up the computer. **Do not test the water-block using city water pressure.** This will bow the top of the housing and render the block unusable (and will void your warranty). **Maximum pressure allowable for testing is 25 psi (1.7 bar)**

Troubleshooting help is available on our web site at www.swiftnets.com, or by calling customer support at 562-595-8009.



Figure 3



Figure 4

Tubes attached with the included worm-drive clamps

IMPORTANT DISCLOSURES

While all efforts have been made to provide the most comprehensive tutorial possible, Swiftech assumes no liability expressed or implied for any damage(s) occurring to your components as a result of using Swiftech cooling products, either due to mistake or omission on our part in the above instructions, or due to failure or defect in the Swiftech cooling products.

WARRANTY

Our products are guaranteed for 12 months from the date of delivery to the final user against defects in materials or workmanship. During this period, they will be repaired or have parts replaced provided that: (I) the product is returned to the agent from which it was purchased; (II) the product has been purchased by the end user and not used for hire purposes; (III) the product has not been **misused**, handled carelessly, or other than in accordance with any instructions provided with respect to its use. This guarantee does not confer rights other than those expressly set out above and does not cover any claims for consequential loss or damage. This guarantee is offered as an extra benefit and does not affect your statutory rights as a consumer.