

MCX-VPro™ Heatsink

I Before you begin :

- Make sure to identify your motherboard properly, as the mounting systems are fundamentally different: 400/533Mhz FSB (Chapter II), or 800Mhz FSB (chapter III)
- Remove the existing cooling solution from your motherboard.
- Clean the CPU with a xylene based cleaner.
- Lightly coat the CPU with the provided Céramique™ thermal compound. Detailed instructions can be found at http://www.arcticsilver.com/ceramique_instructions.htm
- Dual processor side-by-side installation

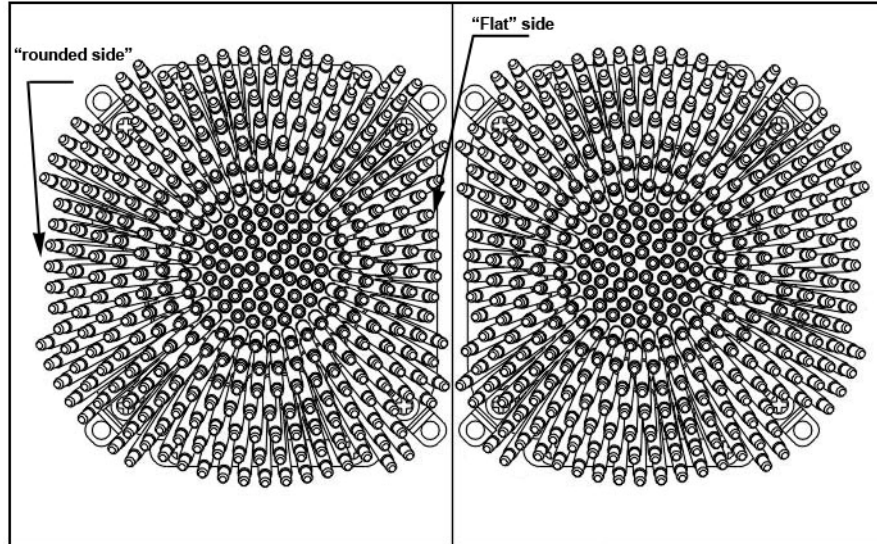

Figure 1

In dual processor “side-by-side” installations make sure to orient the “flat” sides of the heatsinks towards each other. On one side of the heatsink, the outmost row of pins has been removed. This provides clearance for installation of the 2 MCX-VPro heatsinks in side-by-side, dual processor configurations.

- Fan compatibility and installation (fan is not provided)

Use the provided snap-rivets to secure the fan to the bracket thru the lower lip of the fan as shown in the schematic page 1. Fans that do not feature a lip cannot be installed with the provided snap-rivets, and will require a screw and nut to be secured to the brackets.

Recommended fans

Suggested fan airflow rating for normal use (non-overclocked processor), and operating conditions: please visit our web site www.swiftech.com for a list of recommended fans depending on the applications.

II Installation with 400/533 MHz FSB motherboards

Introduction:

- The MCX603-V™ heatsink can either use Intel's validated retention clips, which are **provided with your motherboard (sub-chapter 1)** or it can be installed with Swiftech proprietary mounting system (sub-chapter 2).
- When installed with the Intel clips, removal of the motherboard is not necessary. Please consult your motherboard user's manual for installation of the retention frame and clip.
- For installation with 800Mhz FSB motherboards, please go to chapter III.

1. Installation with Intel clips

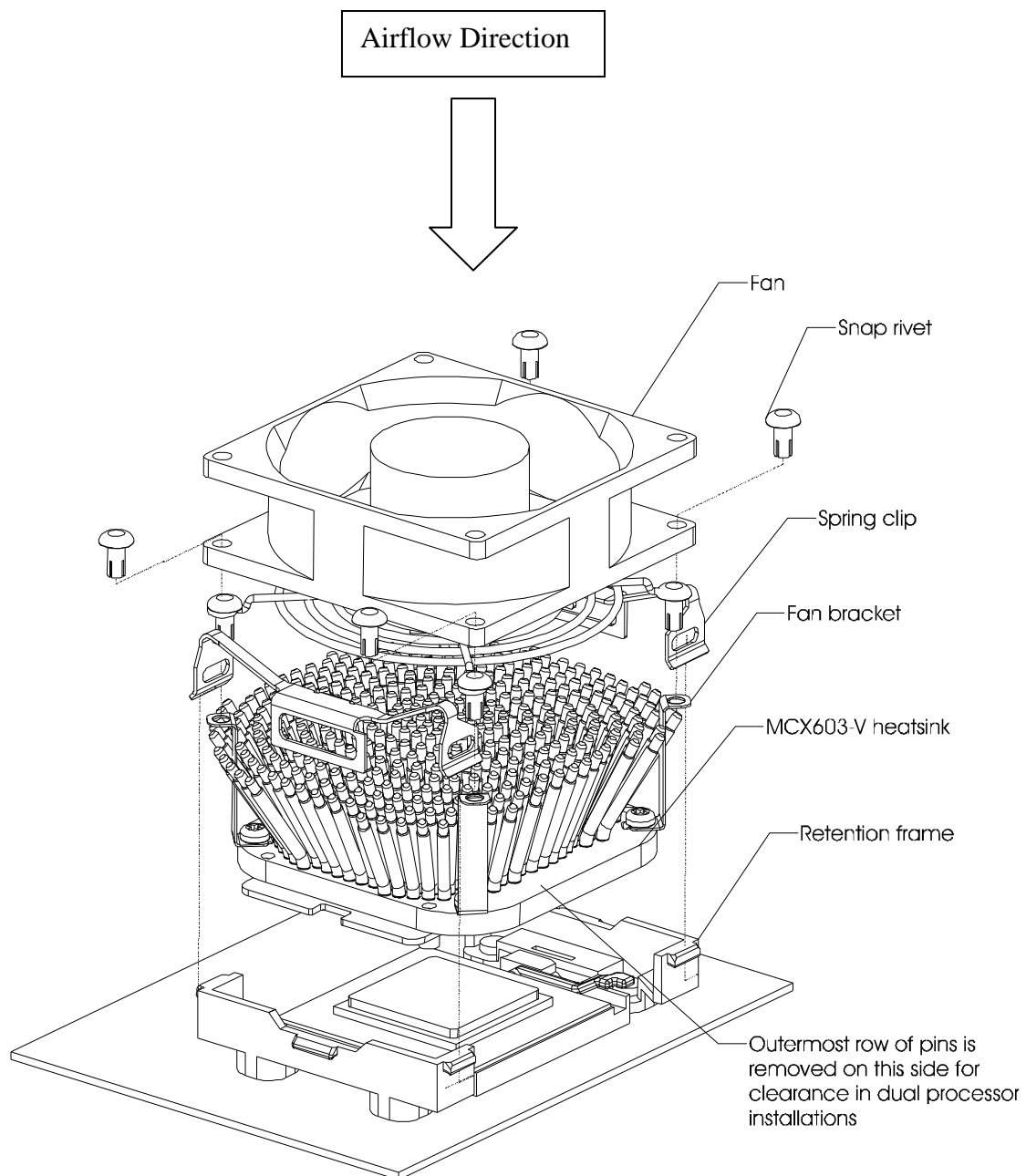

Figure 2

- **Note:** on one side of the heatsink, the outermost row of pins has been removed. This provides clearance for installation of two MCX603-V™ heatsinks in side-by-side, dual processor configurations.

2. Installation with Swiftech mounting system

- Remove the motherboard from the chassis, and remove the stock retention frames to expose the mounting holes.
- Install the standoffs through the holes, using fiber washers and locknuts as shown in figure 2
- Tighten the standoffs as shown figure 1, using a ¼" socket tool to drive the standoff, and a small pair of pliers to prevent the locknut from spinning. Torque value should not to exceed 16 in. lbs. In other words just tight, without excessive torque, otherwise the standoff stem may snap.



Figure 3

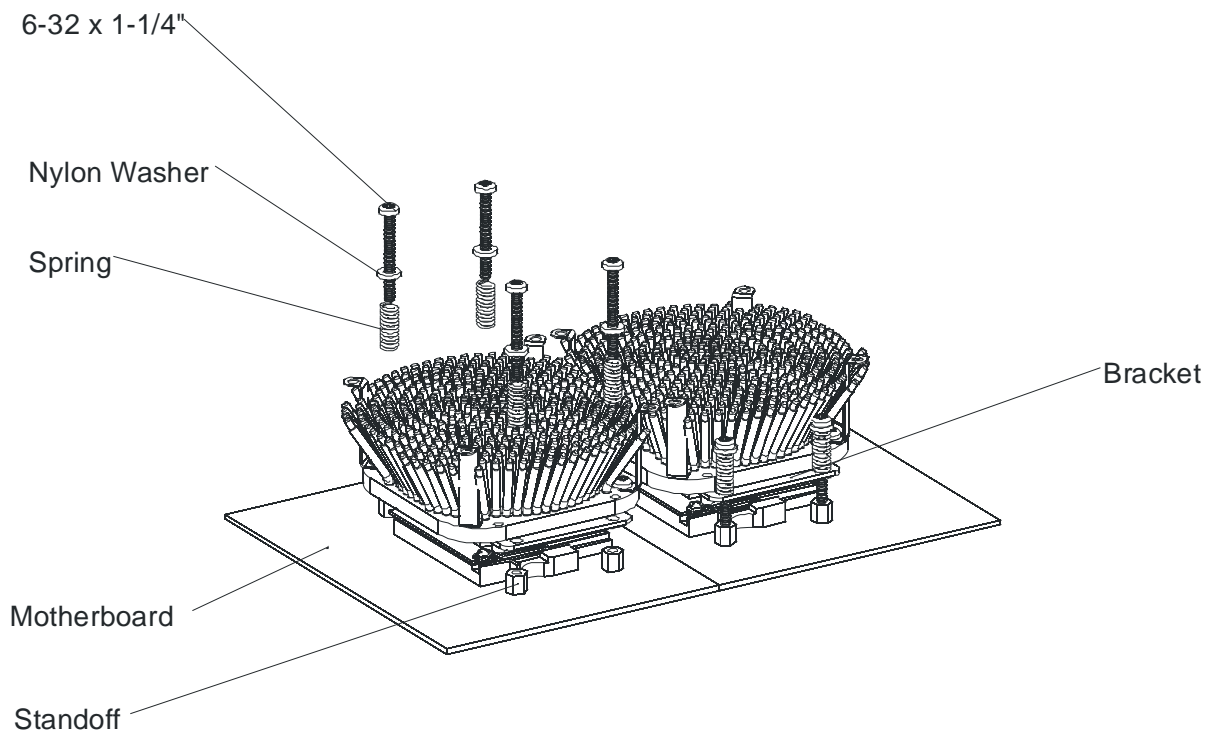

Tighten the spring loaded screws in a crisscross pattern until the screws bottom out into the standoff. Once there, do not attempt to lock the screws any further or they will jam out the standoff, and could prove difficult to remove if you ever need to uninstall the heat sink. Installation is now complete.

III Installation with 800 MHz FSB motherboards (most recent motherboards)

Use the provided 7/64 ball point hex key to very gradually tighten the 4 socket screws in a cross pattern.

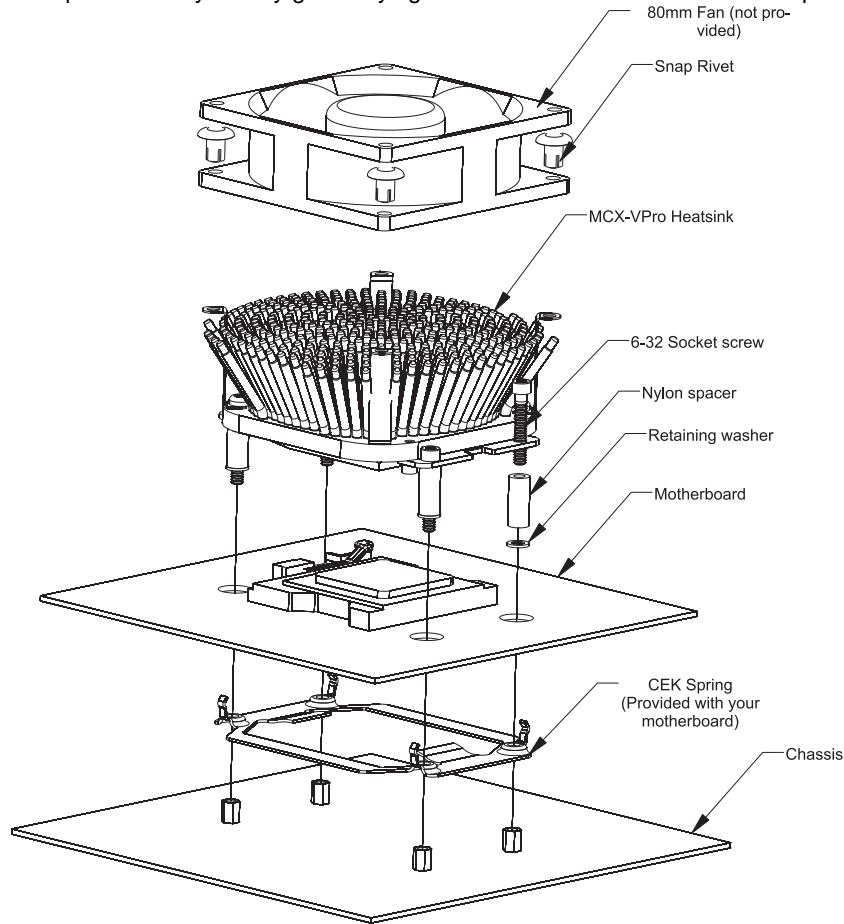

IV. Heatsink removal

Warning! Hydraulic suction causes the heatsink to strongly adhere to the processor. Do not attempt to lift the heatsink off without loosening its bond from the processor first!

- Use the provided 7/64 ball-point hex key to very gradually unscrew the 4 socket screws in a cross pattern.
- Hold the heatsink between finger and index, and gently wriggle it to loosen it from the CPU (do not use excessive force when wriggling the heatsink)
- Once the CPU is loosened from the heatsink, slide it off in the horizontal plane as much as space permits, and then lift it up.
- Clean the surface of the CPU and the heatsink to get rid of old thermal compound. Reapply the proper amount of thermal compound on the CPU surface before you re-install the heatsink.

IMPORTANT DISCLOSURES

While all efforts have been made to provide the most comprehensive tutorial possible, Swiftech assumes no liability expressed or implied for any damage(s) occurring to your components as a result of using Swiftech cooling products, either due to mistake or omission on our part in the above instructions, or due to failure or defect in the Swiftech cooling products.

WARRANTY

Our products are guaranteed for 12 months from the date of delivery to the final user against defects in materials or workmanship. Pump is guaranteed for 24 months. During this period, they will be repaired or have parts replaced provided that: (I) the product is returned to the agent from which it was purchased; (II) the product has been purchased by the end user and not used for hire purposes; (III) the product has not been **misused**, handled carelessly, or other than in accordance with any instructions provided with respect to its use. This guarantee does not confer rights other than those expressly set out above and does not cover any claims for consequential loss or damage. This guarantee is offered as an extra benefit and does not affect your statutory rights as a consumer.