

MCX159-P™ Heatsink fan Intel® Platforms - Installation Guide

Packing list

Parts	Qty	Parts	Qty
Heat Sink	1	Wire-Spring	1
40mm fan	1	Thermal grease – Arctic Alumina	1
Neoprene pads (strip of 4)	1		

Heatsink fan Installation

1. Installation does **not** necessitate removal of the motherboard from the chassis.
2. Remove the existing heatsink and carefully clean the microprocessor with alcohol
3. Lightly coat the processor core with the provided Arctic Alumina® thermal compound. **Only a paper-thin coat is necessary!** It should be applied using preferably a razor blade, or a credit card, held between thumb and index at a 45° angle.
4. Install the provided neoprene pads onto the processor as shown figure 1. The pads must not be installed on chipsets featuring a heat spreader as shown figure 2.

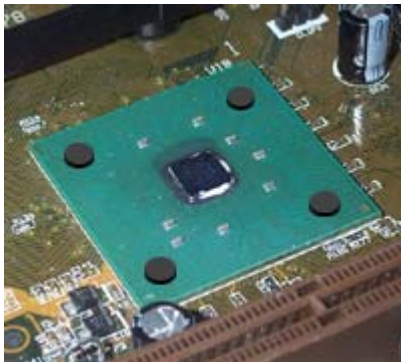

Figure 1 – Neoprene pads required



Figure 2 – Neoprene pads **MUST NOT** be installed

5. Install the heatsink fan onto the processor as shown Figure 3 by simply engaging one end of the hook into a motherboard retention loop then engaging the opposite hook. Make sure that the heatsink is centered between the two arms of the wire-spring.

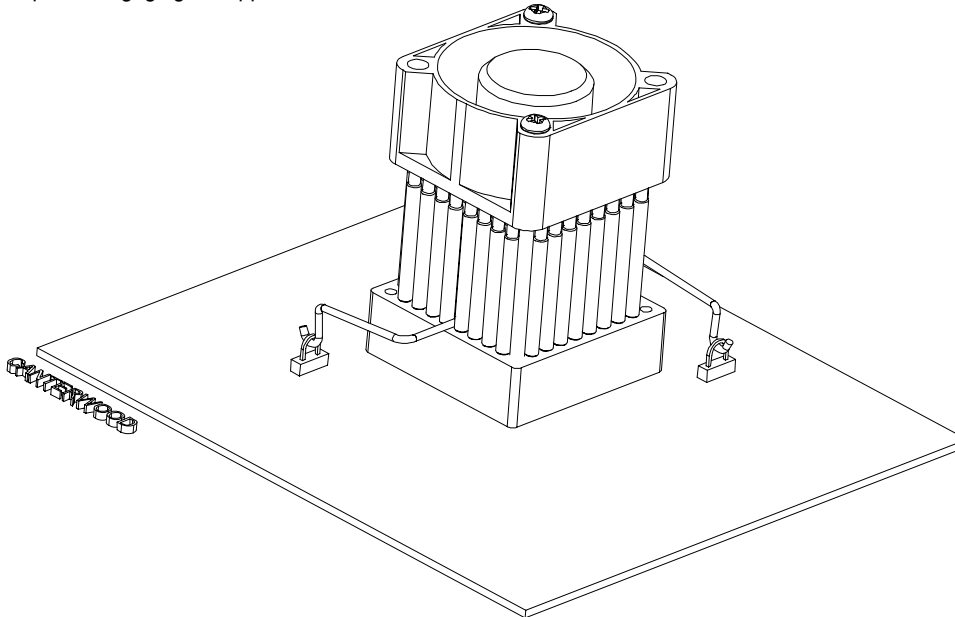

Figure 3

6. Connect the fan to any motherboard 3-pin power connector.

Installation is complete!

IMPORTANT DISCLAIMER

Copyright Swiftech 2003 – All rights reserved – Last revision date: Sep 15, 2003
 Rouchon Industries, Inc., dba Swiftech – 1703 E. 28th Street, Signal Hill, CA 90755 – Tel. 562-595-8009 – Fax 562-595-8769
 E Mail: Swiftech @swiftnets.com – URL: <http://www.swiftnets.com>

While all efforts have been made to provide the most comprehensive tutorial possible, Swiftech assumes no liability expressed or implied for any damage(s) occurring to your components as a result of using Swiftech cooling products, either due to mistake or omission on our part in the above instructions, or due to failure or defect in the Swiftech cooling products.

WARRANTY

Our products are guaranteed for 12 months from the date of delivery to the final user against defects in materials or workmanship. During this period, they will be repaired or have parts replaced provided that: (I) the product is returned to the agent from which it was purchased; (II) the product has been purchased by the end user and not used for hire purposes; (III) the product has not been **misused** (*), handled carelessly, or other than in accordance with any instructions provided with respect to its use. This guarantee does not confer rights other than those expressly set out above and does not cover any claims for consequential loss or damage. This guarantee is offered as an extra benefit and does not affect your statutory rights as a consumer.