



MCX603-V™ Heatsink

Installation Guide For Intel® Xeon™ processors

Packing list

Parts	Qty	Parts	Qty
Heat Sink	1	Push-pin rivets (standard)	4
80mm fan brackets	4	Thermal grease – Céramique	1

1. Processor Preparation

Lightly coat the CPU with the provided Céramique™ thermal compound. Detailed instructions can be found at http://www.arcticsilver.com/ceramique_instructions.htm



Rub some compound in base of water-block first, and then clean off with lint-free cloth.



Apply small amount of compound on the CPU heat spreader

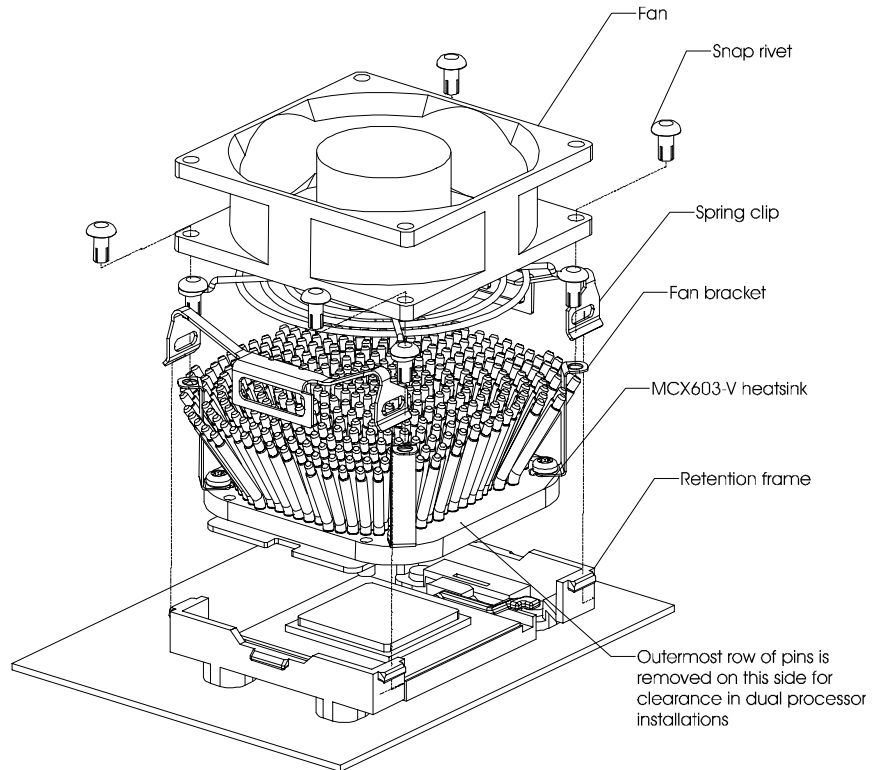

2. Heatsink installation

The MCX603-V™ heatsink uses Intel's validated retention clips, which are **provided with your motherboard**. It does not necessitate removal of the motherboard. Please consult your motherboard user's manual for installation of the retention frame and clips.

Note: on one side of the heatsink, the outmost row of pins has been removed. This provides clearance for installation of two MCX603-V™ heatsinks in side-by-side, dual processor configurations.

Simply place the heatsink onto the CPU, and push down on the spring clips to secure the assembly.

TIP: press down on the opposite side of the heatsink while installing the first clip, to prevent the assembly from tilting.

3. Alternate retention

Swiftech's optional proprietary retention mechanism (spring loaded screws & standoffs) is also available online. Information is available on our site [here](#).

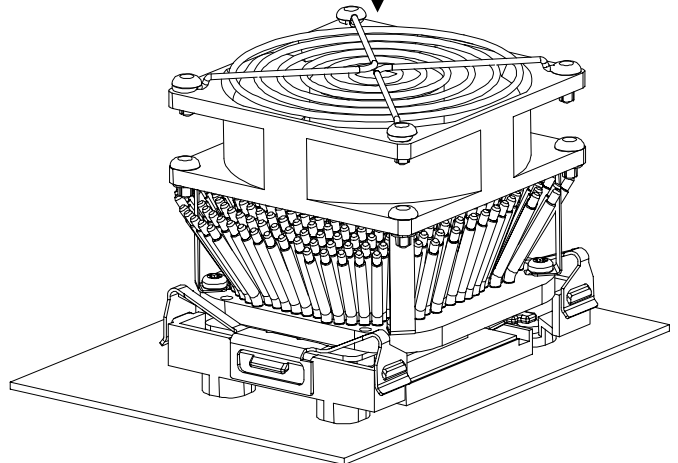
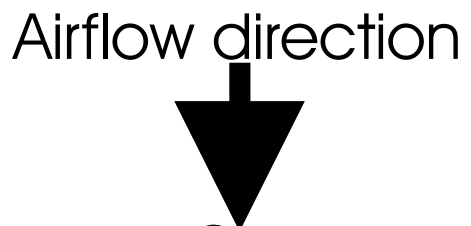

4. Dual processor side-by-side installation

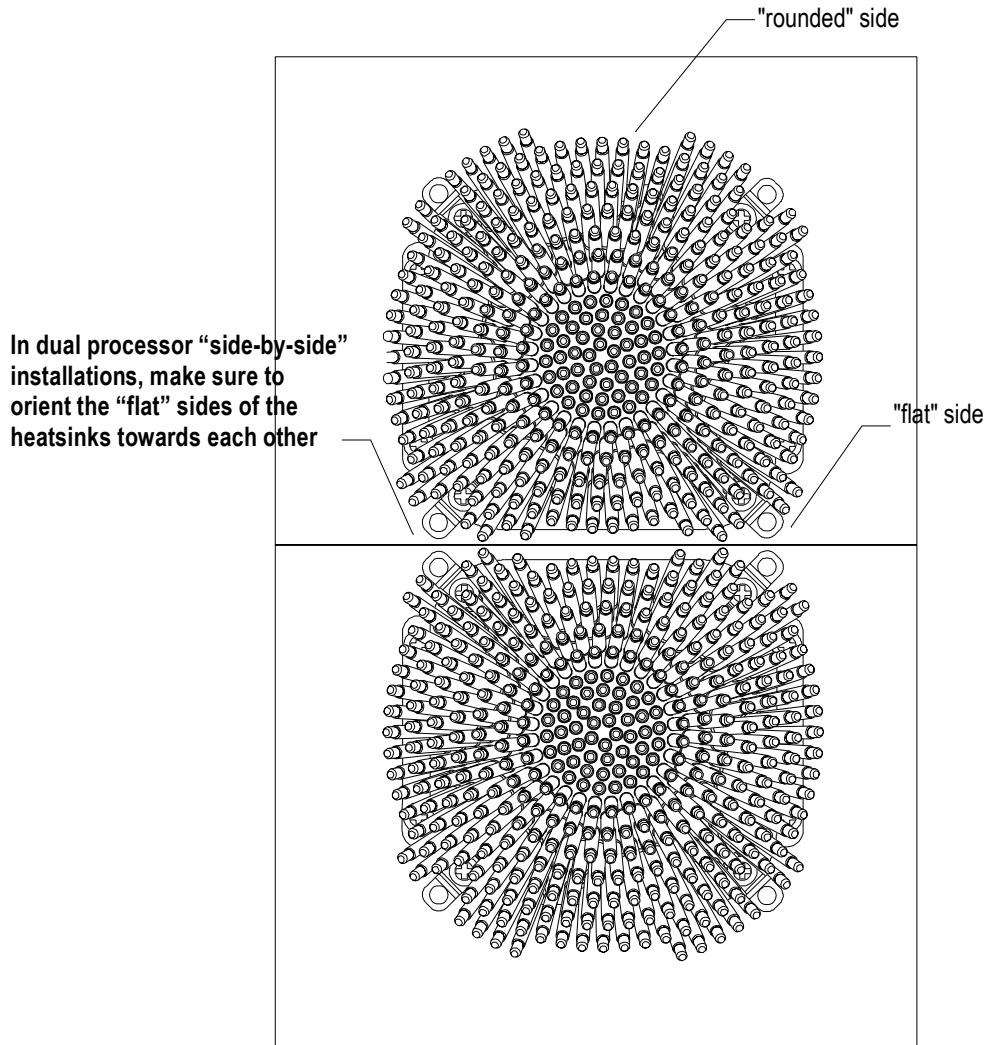

5. Fan compatibility and installation (fan is not provided)

Use the provided snap-rivets to secure the fan to the bracket thru the lower lip of the fan as shown in the schematic page 1. Fans that do not feature a lip cannot be installed with the provided snap-rivets, and will require a screw and nut to be secured to the brackets.

6. Recommended fans

Suggested fan airflow rating for normal use (non-overclocked processor), and operating conditions: please visit our web site [here](#) for a list of recommended fans depending on the applications.

7. Final inspection

Now that the heat sink is installed, startup your computer, go into the BIOS and observe the CPU temperature. Under normal ambient temperature conditions, the processor temperature should never exceed 65° C. If it does, shut down the computer immediately, and review your entire installation. Troubleshooting help is available on our web site at www.swiftnets.com, or by calling customer support at 562-595-8009.

MCX603-V Installation with optional screw/spring assemblies – (part # MCX603-VSR2)

Remove the motherboard from the chassis, and remove the stock retention frames to expose the mounting holes.

Install the standoffs though the holes, using fiber washers and locknuts as shown in figure 2

Tighten the standoffs as shown figure 1, using a ¼" socket tool to drive the standoff, and a small pair of pliers to prevent the locknut from spinning. Torque value should not to exceed 16 in. lbs. In other words just tight, without excessive torque, otherwise the standoff stem may snap.



Figure 1

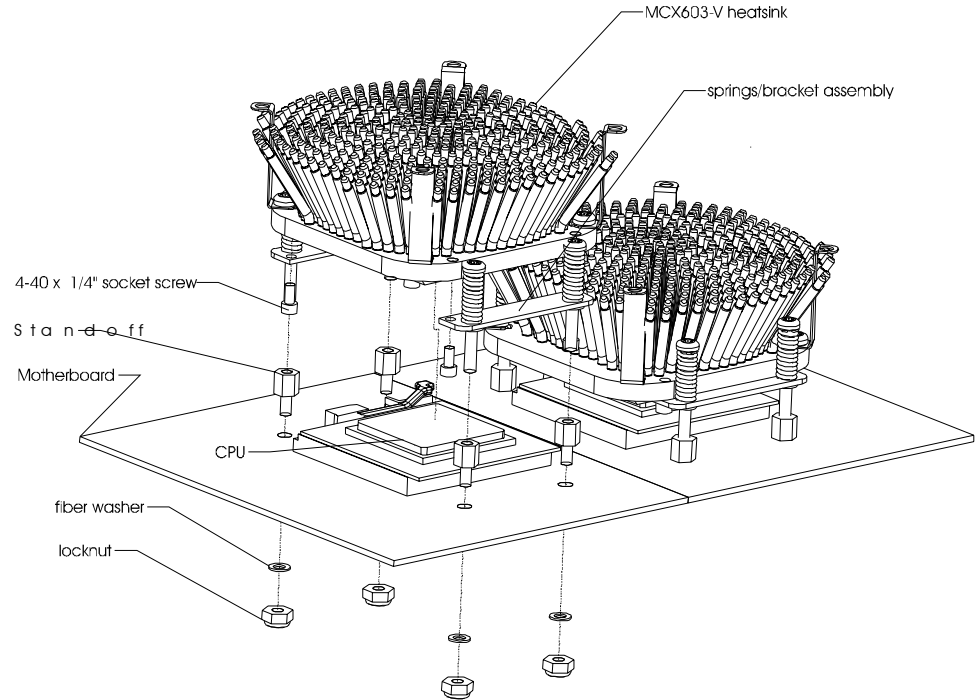

Figure 2

Tighten the spring-loaded screws in a crisscross pattern until the screws bottom out into the standoff. Once there, do not attempt to lock the screws any further, or they will jam into the standoff, and could prove difficult to remove if you ever need to uninstall the heatsink. **Installation is now complete.**

IMPORTANT DISCLOSURES

While all efforts have been made to provide the most comprehensive tutorial possible, Swiftech assumes no liability expressed or implied for any damage(s) occurring to your components as a result of using Swiftech cooling products, either due to mistake or omission on our part in the above instructions, or due to failure or defect in the Swiftech cooling products.

WARRANTY

Our products are guaranteed for 12 months from the date of delivery to the final user against defects in materials or workmanship. Pump is guaranteed for 24 months. During this period, they will be repaired or have parts replaced provided that: (I) the product is returned to the agent from which it was purchased; (II) the product has been purchased by the end user and not used for hire purposes; (III) the product has not been **misused**, handled carelessly, or other than in accordance with any instructions provided with respect to its use. This guarantee does not confer rights other than those expressly set out above and does not cover any claims for consequential loss or damage. This guarantee is offered as an extra benefit and does not affect your statutory rights as a consumer.